

## 05-341 Removal and installation of guiding rails

Preceding work:  
Poly-V belt removed (13-345).  
Chain tensioner removed (05-310).

Operation no. of operation texts and work units  
of standard texts and flat rates .....

### A. Removal and installation of guiding rail in cylinder head

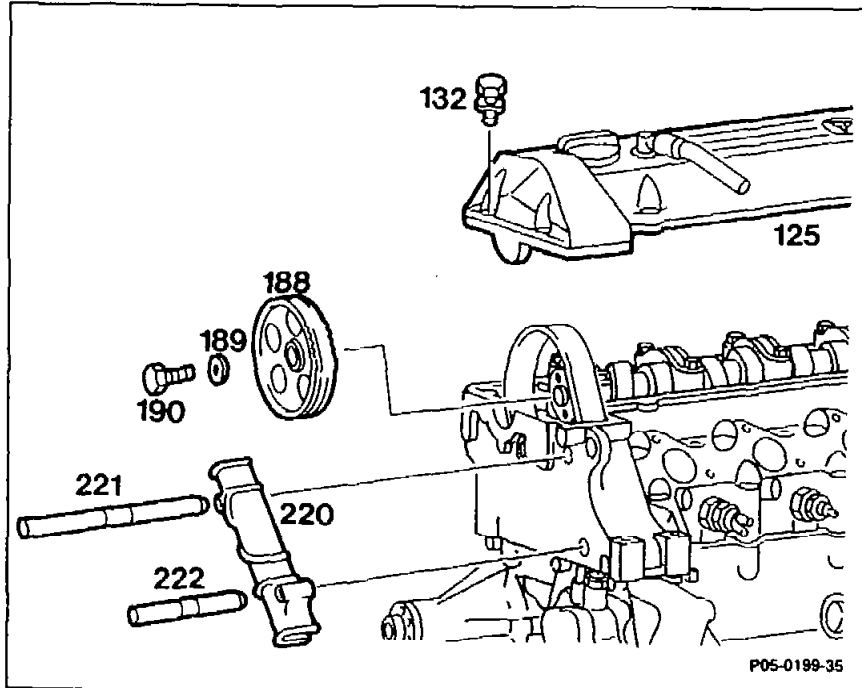

#### Turbo engines

Boost air pipe ..... remove, install.

#### Engine 601 in model 202

Air cleaner cross pipe ..... remove, install.

Cylinder head cover (125) ..... remove, install, bolt (132) 10 Nm.

#### With self-levelling suspension:

Pressure oil pump drive ..... remove, install (05-437).

Camshaft timing gear (188) ..... mark at timing chain. Remove, install camshaft timing gear. Different bolts (190) and washers (189) with different tightening torques. Hexagon bolt 65 Nm. 12-point bolt 25 Nm/90° (05-220) (Numbers 3 - 5).

Bearing pins (221, 222) ..... remove, install.  
 Special tools 116 589 20 33 00 and  
 116 589 01 34 00.  
 Check guiding rail (220), replace if necessary.  
 (Number 6).



The extractor 115 589 20 33 00 can be used  
 together with stud 116 589 01 34 00 if the  
 bearing pins have seized.

<b>Tightening torques and tightening angle</b>	<b>Nm</b>	
Hexagon bolts on cylinder head cover	10	
Hexagon bolt on camshaft timing gear	65	
12-point bolt on camshaft timing gear	25	90°

### Special tools

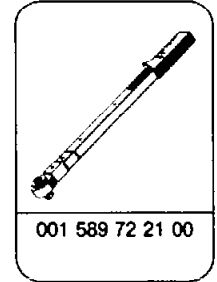
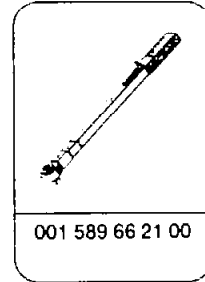
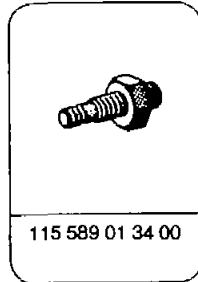
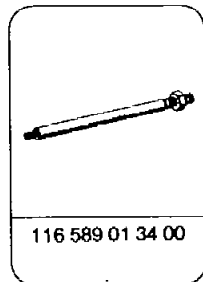
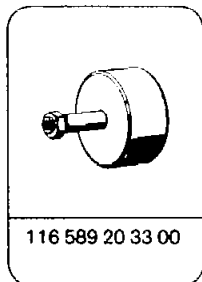

## Removal

---

- 1 Remove cylinder head cover.

### With self-levelling suspension:

- 2 Remove pressure oil pump drive (05-437).

- 3 Mark relative positions of timing chain and camshaft timing gear.

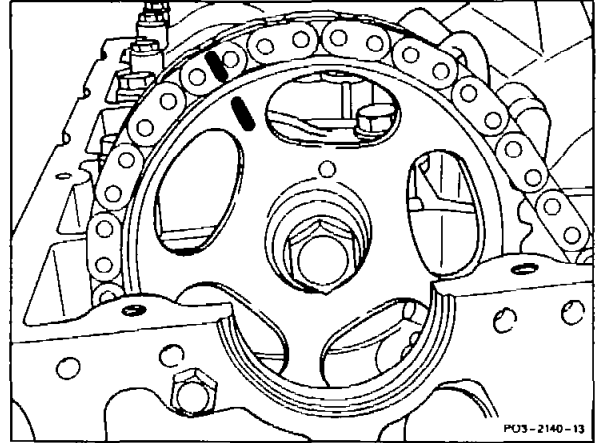

- 4 Unscrew hexagon bolt or 12-point bolt on camshaft timing gear, holding camshaft with a mandrel.

- 5 Remove camshaft timing gear and allow timing chain to sag.



Note different bolt and washer (05-220).

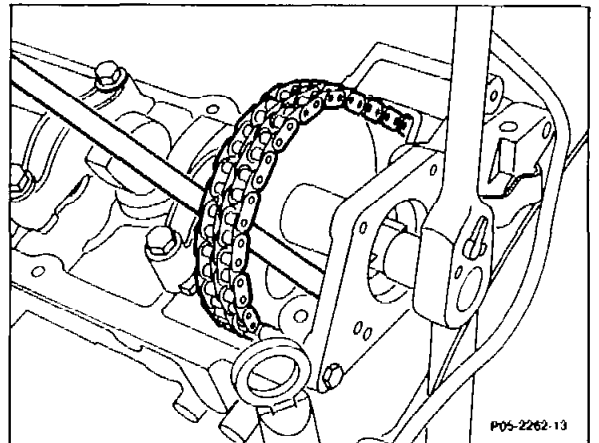

- 6 Drive out both bearing bolts with the impact puller 116 589 20 33 00, and 116 589 01 34 00 and remove guiding rail. Check guiding rail and replace if necessary.



Seized bearing bolts can also be pulled out with puller 115 589 20 33 00 and stud 115 589 01 34 00.

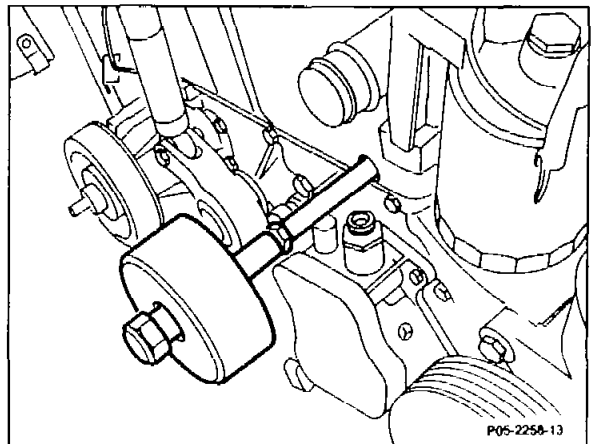

## Installation

- 7 Coat bearing pin collar with sealing compound.
- 8 Insert guiding rail and drive home bearing pin with impact puller 116 589 20 33 00 and 116 589 01 34 00.

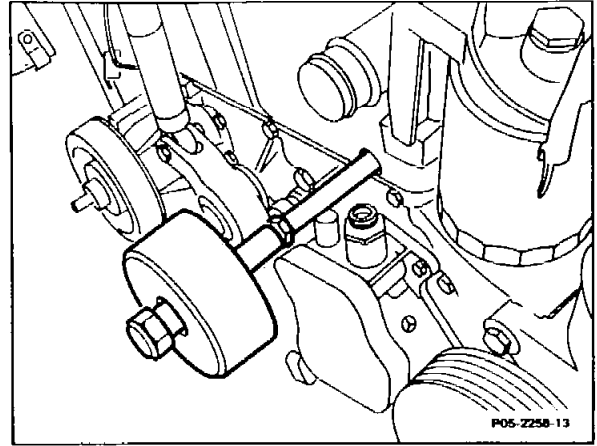

- 9 Install camshaft timing gear according to the marking and tighten, noting the color markings.

Tightening torque and tightening angle  
Hexagon bolt                    65 Nm,  
12-point bolt                    25 Nm, 90°.

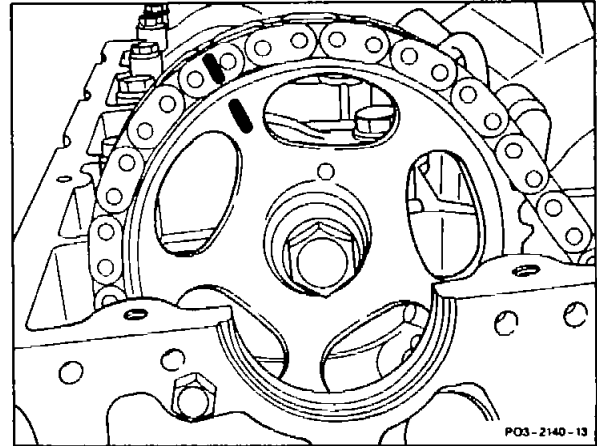

- 10 Position engine on ignition TDC of No. 1 cylinder and check marking (arrows).



Do not crank engine by camshaft timing gear bolt.

### With self-levelling suspension:

- 11 Install pressure oil pump drive (05-437).
- 12 Install cylinder head cover, 10 Nm.

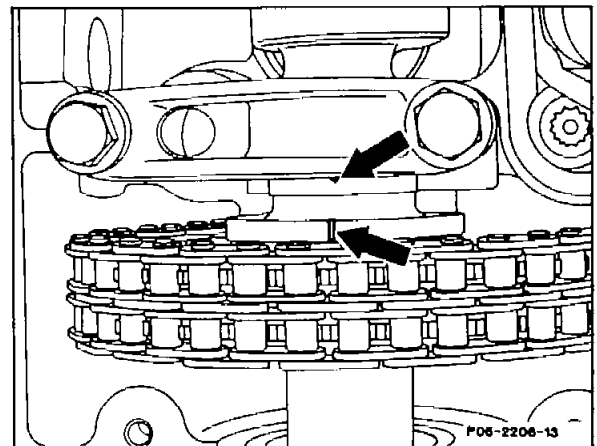

Preceding work:  
Timing case cover removed (01-210).  
Chain tensioner removed (05-310).

## B. Removal and Installation of guiding rail in timing case

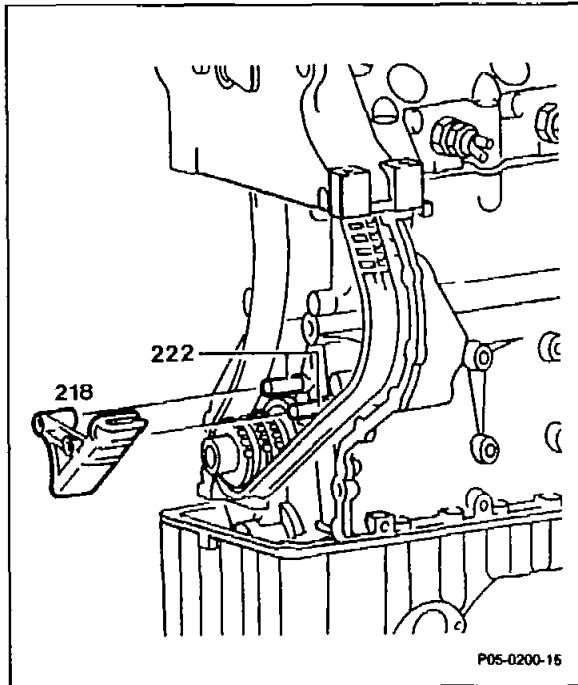

Guiding rail (218) ..... pull off from guiding rail bolt (222), put on.  
Check guiding rail, replace if necessary.

### Note

Since 09/86 unhardened straight pins have been fitted for the guiding rail bearing.