

32-0610 Removing and installing rear axle spring struts

Preceding work:
Pressure oil system emptied (32-0630)..

Operation no. of operation texts and work units or standard texts
and flat rates:
32-0780

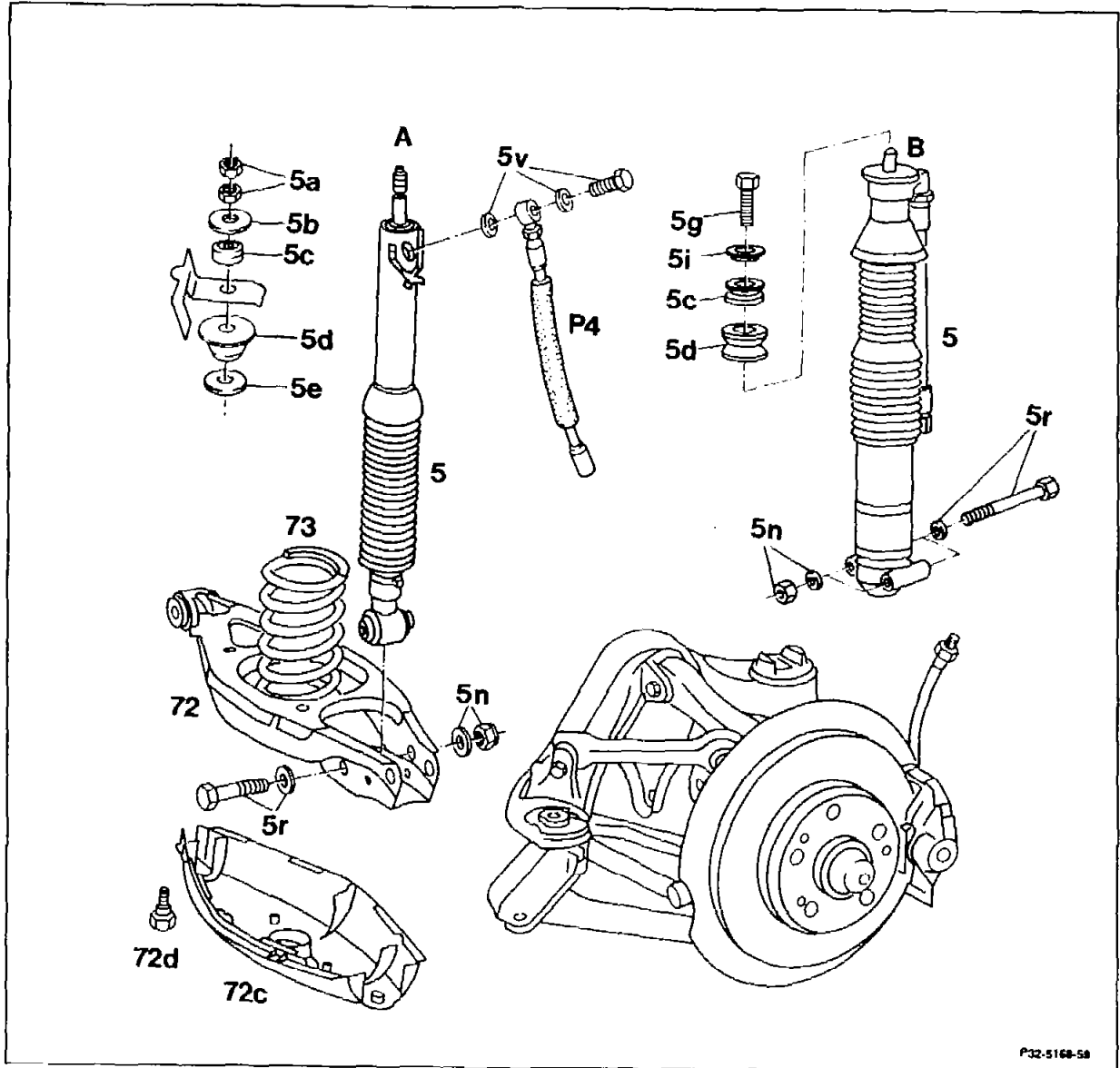

Version A
(model 124 Coupé, Cabriolet, Sedan and
model 201)

Trunk lining Remove, install (68-480)



The vehicle must be standing on its wheels or
have its spring link supported.

Hexagon nut (5a) of upper mounting	Unscrew, screw on. Remove, install washer (5b) and rubber mount (5c) (steps 2 and 4). 4). When installing, tighten the lower hexagon nut (5a) to 25 ± 5 Nm, then lock with the upper hexagon nut (5a), 25 ± 5 Nm. Ensure that the rubber mount (5c) is correctly seated.
Vehicle	Raise, lower (00–9008).
Pressure line (P4)	Disconnect, connect. Ensure that it is correctly routed (step 10). Use new solid copper sealing rings (5v). M12 × 1.5: 25 Nm, M14 × 1.5: 30 Nm, M16 × 1.5: 30 Nm.
Hexagon bolts (72d)	Unscrew, screw in. Remove, install spring link cover (72c) (step 11).
Self-locking hexagon nut (5n)	Unscrew, screw on, replace, 60 Nm. Remove, install hexagon bolt and washer (5r) (step 12).
Spring strut (5)	Remove, install. Remove, install lower rubber mount (5d) and plate (5e). Ensure correct installed position (see installation instructions for model 201).

**Version B
(model 124 T-model)**

Loading area cover	Remove, install.
	 The vehicle must be standing on its wheels or have its spring link supported.
Self-locking hexagon bolt (5g)	Unscrew, screw in, replace, 25 Nm (step 6).
Washer (5i) and upper rubber mount (5c)	Remove, install (step 6).
Vehicle	Raise, lower (00–9008).

Pressure line (P4)	Disconnect, connect. Ensure that it is correctly routed (step 10). Use new solid copper sealing rings (5v). M12 × 1.5: 25 Nm, M14 × 1.5: 30 Nm, M16 × 1.5: 30 Nm.
Hexagon bolts (72d)	Unscrew, screw in. Remove, install spring link cover (72c) (step 11).
Self-locking hexagon nuts (5n)	Unscrew, screw on, replace, 60 Nm. Remove, install hexagon bolts and washers (5r) (steps 12 and 13).
Spring strut (5)	Remove, install. Remove, install lower rubber mount (5d). Ensure correct installed position.

Special tools

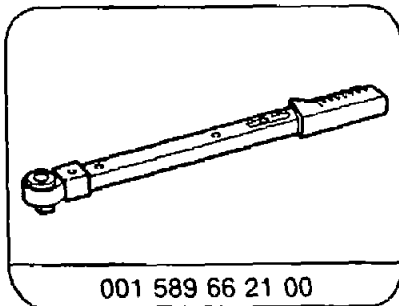

Note

The spring struts simultaneously act as rebound stops for the rear wheels. Therefore only disconnect the upper mountings when the vehicle is standing on its wheels or the spring link is supported.

If the spring strut tube rotates when screwing on the hexagon nuts, hold it firmly in the wheelhouse. A flat open-end wrench (WAF 17 and approx. 5 mm thick) is required to slacken the lock nut.

Removing and installing

Model 124 Coupé, Sedan and model 201

- 1 Remove trunk lining (68-480).
- 2 Unscrew hexagon nuts (5a) and remove washer (5b) and upper rubber mount (5c).

Installation notes

Tighten lower hexagon nut to 25 ± 5 Nm, then lock with upper hexagon nut to 25 ± 5 Nm. Ensure that the rubber mount (5c) is correctly seated.

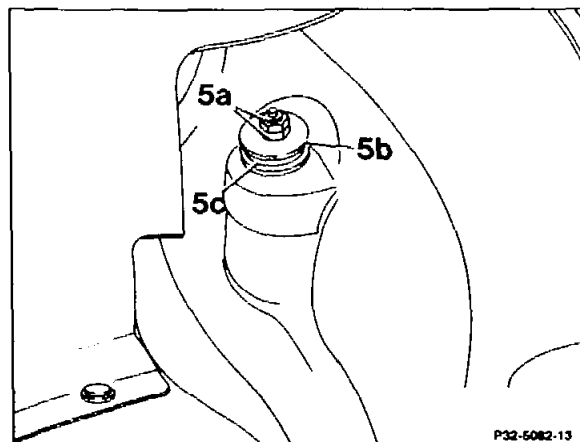

Model 124 Cabriolet

- 3 Remove lining in soft top compartment.
- 4 In assembly opening, unscrew hexagon nuts (5a) and remove washer (5b) and upper rubber mount (5c).

Assembly opening in soft top compartment

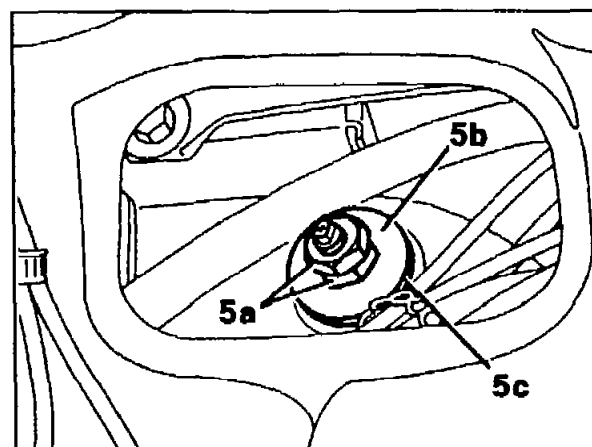

Model 124 T-model

- 5 Remove loading area cover (70a).
- 6 Unscrew self-locking hexagon bolt (5g) and remove washer (5i) and upper rubber mount (5c).

Installation notes

Replace self-locking hexagon bolt, 25 Nm.

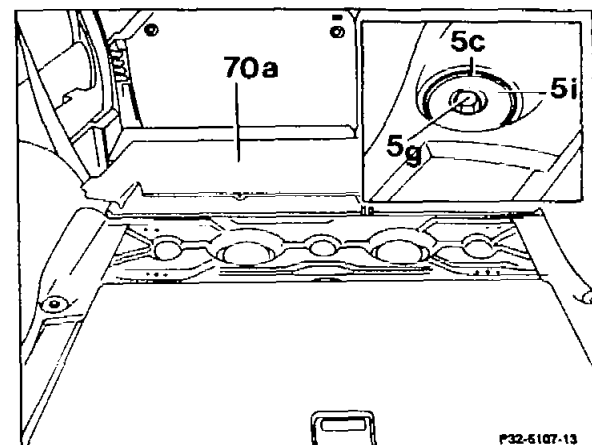

Model 124 with special body

7 Remove flap on front side of delivery area.
Remove base plate if required.

8 Unscrew self-locking hexagon bolt and
remove plate and upper rubber mount.

Installation notes

Replace self-locking hexagon bolt, 25 Nm.

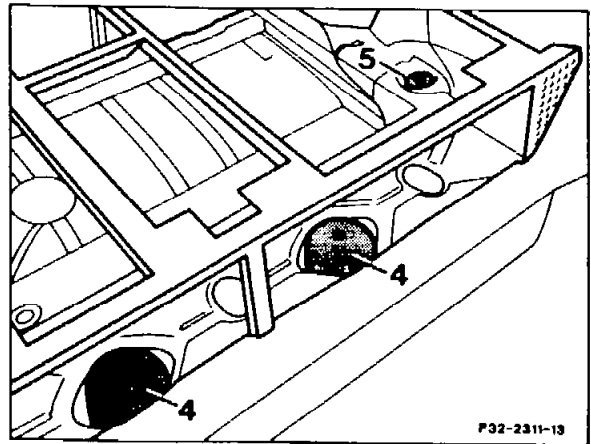

All models

9 Raise vehicle at rear axle.

10 Disconnect pressure line (P4) at connection
of steel line to pressure hose and seal off line
connections with suitable plugs.

Installation notes

Replace solid copper sealing rings. .

M12 x 1.5: 25 Nm,

M14 x 1.5: 30 Nm,

M16 x 1.5: 30 Nm.

Check line connections for leaks.

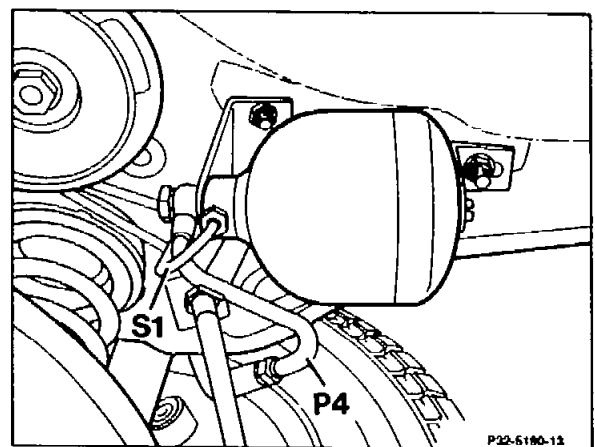

Arrangement on model 201

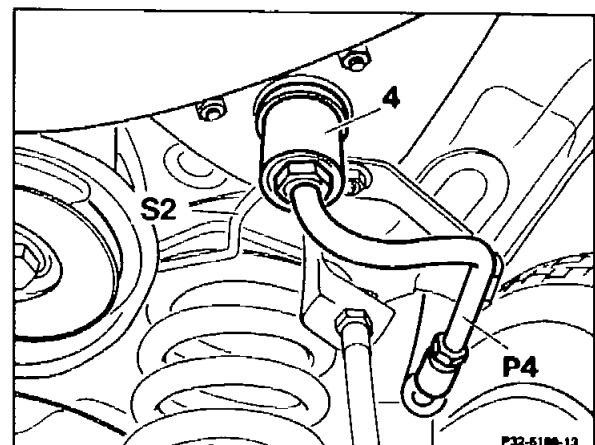

Arrangement on model 124 Coupé, Cabriolet and
Sedan

Arrangement on model 124 T-model and vehicles with special bodies

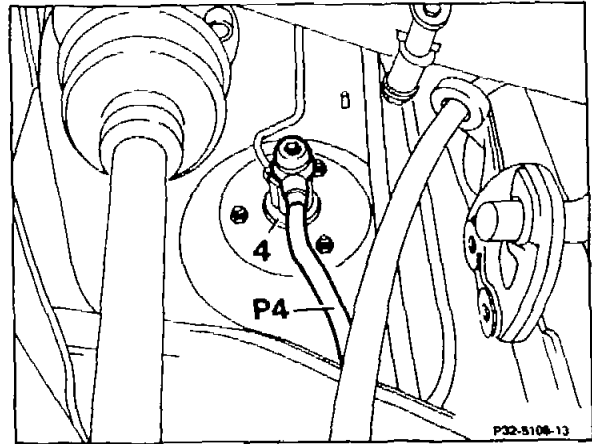

11 Unscrew two hexagon bolts (arrows) and remove spring link cover (72c).

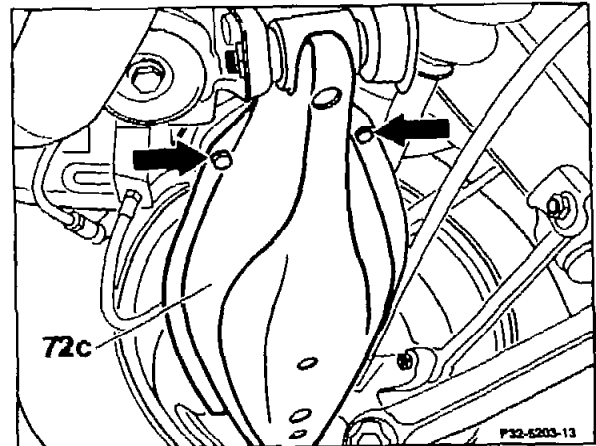

Model 124 Coupé, Cabriolet, Sedan and model 201

12 Unscrew self-locking hexagon nut (5n) and remove hexagon bolt and washer (5r).

Installation note

Replace self-locking hexagon nut, 60 Nm.

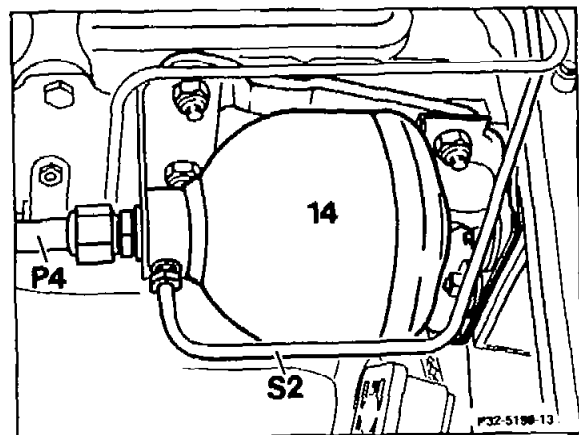

Model 201

The distance "a" between the bracket on the spring strut tube and the wheelhouse (70c) is a prerequisite for correct assembly.

Distance "a":

In the rebound condition: 3 ± 1 mm.

In the ready-to-drive condition (vehicle standing on its wheels): 6 ± 1 mm.

The spring strut can only be aligned when the screwed connection between the pressure hose and the steel line (P4) is unscrewed.

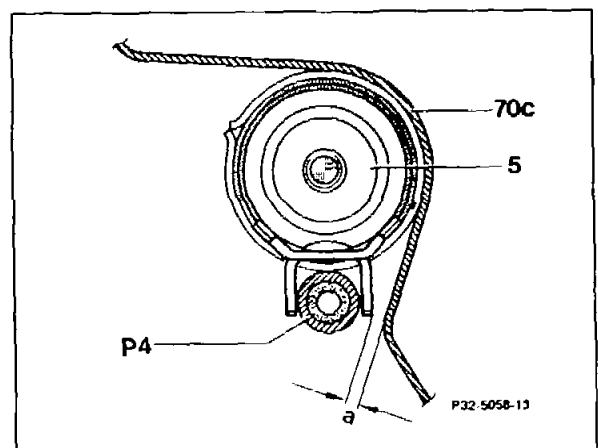

Model 124 T-model and vehicles with special bodies

13 Unscrew self-locking hexagon nuts (5n) and remove hexagon bolts and washers.

Installation notes

Replace self-locking hexagon nuts, 60 Nm.

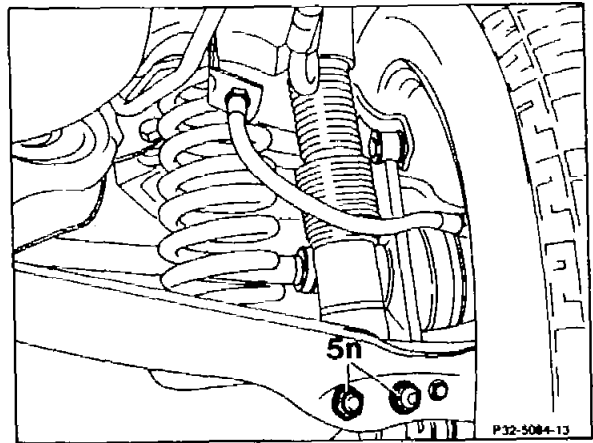

All models

14 Press spring strut (5) down and out of mounting bore in frame floor. Take spring strut out of spring link, pull down and remove.

Installation note

Check mounting parts and rubber sleeves of spring strut and replace spring strut (5) if necessary. .

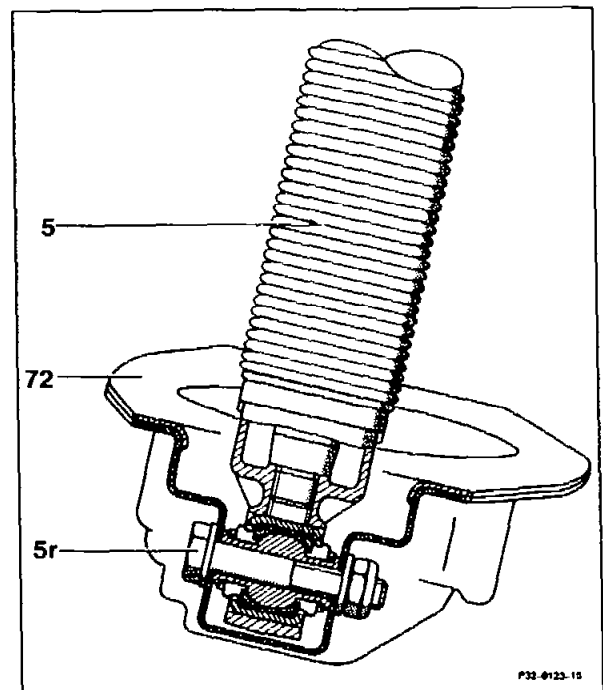

- 5 Spring strut
- 5r Hexagon bolt with washer
- 72 Spring link

15 Check attachment parts.

Note

The banjo bolts (B) for fixing the pressure line to the spring actuator and spring strut must be checked for cracks in the area of the stem (arrow).

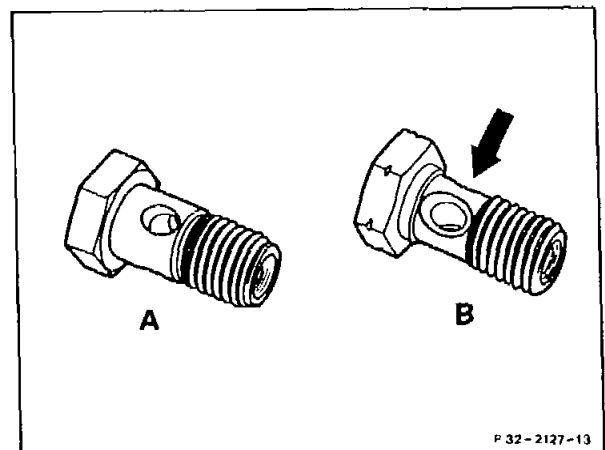

Version up to 08/87

Arrangement on model 124 Coupé, Sedan and model 201

- 5 Spring strut
- 5a Hexagon nuts
- 5b Upper washer
- 5c Upper rubber mount
- 5d Lower rubber mount
- 5e Plate
- 5n Self-locking hexagon nut with washer
- 5r Hexagon bolt with washer
- 5r Hexagon bolt with washer
- P4 Pressure hose, spring actuator - spring strut

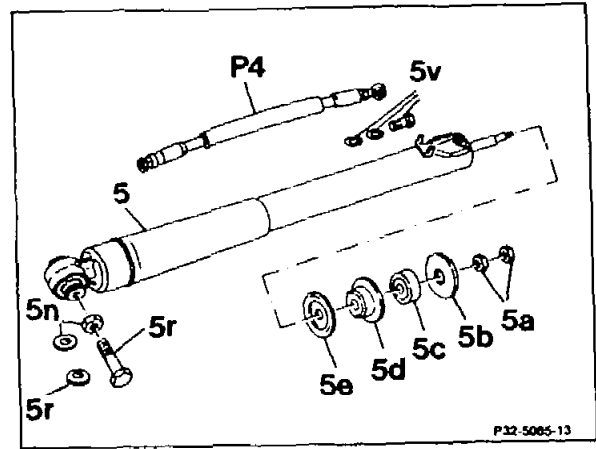

Version as of 09/87

Arrangement on model 124 Coupé, Cabriolet, Sedan and model 201

- 5 Spring strut
- 5a Hexagon nuts
- 5b Upper washer
- 5c Upper rubber mount
- 5d Lower rubber mount
- 5e Plate
- 5n Self-locking hexagon nut with washer
- 5r Hexagon bolt with washer
- P4 Pressure hose, spring actuator - spring strut

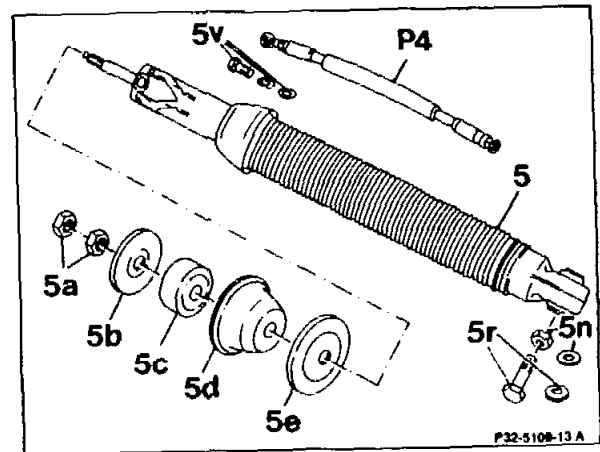

Arrangement on model 124 T-models and vehicles with special bodies

- 5 Spring strut
- 5c Upper rubber mount
- 5d Lower rubber mount
- 5g Hexagon bolt (micro-encapsulated)
- 5i Plate
- 5n Self-locking hexagon nuts with washers
- 5r Hexagon bolts with washers
- P4 Pressure hose, spring actuator - spring strut

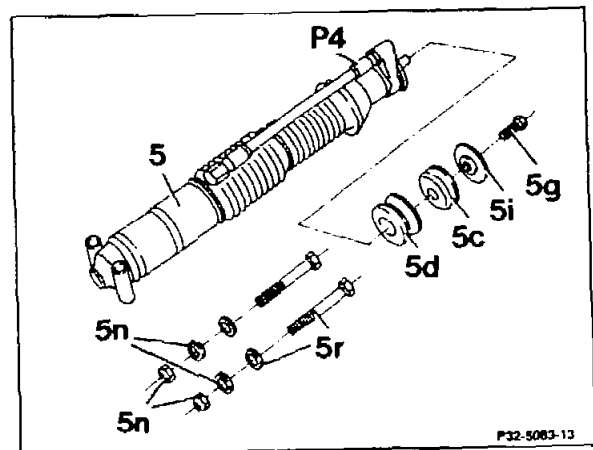

16 Install in the reverse sequence.