

33-0310 Removing and installing front wheel hub

Preceding work:
Removing and installing front wheel (40-1450)

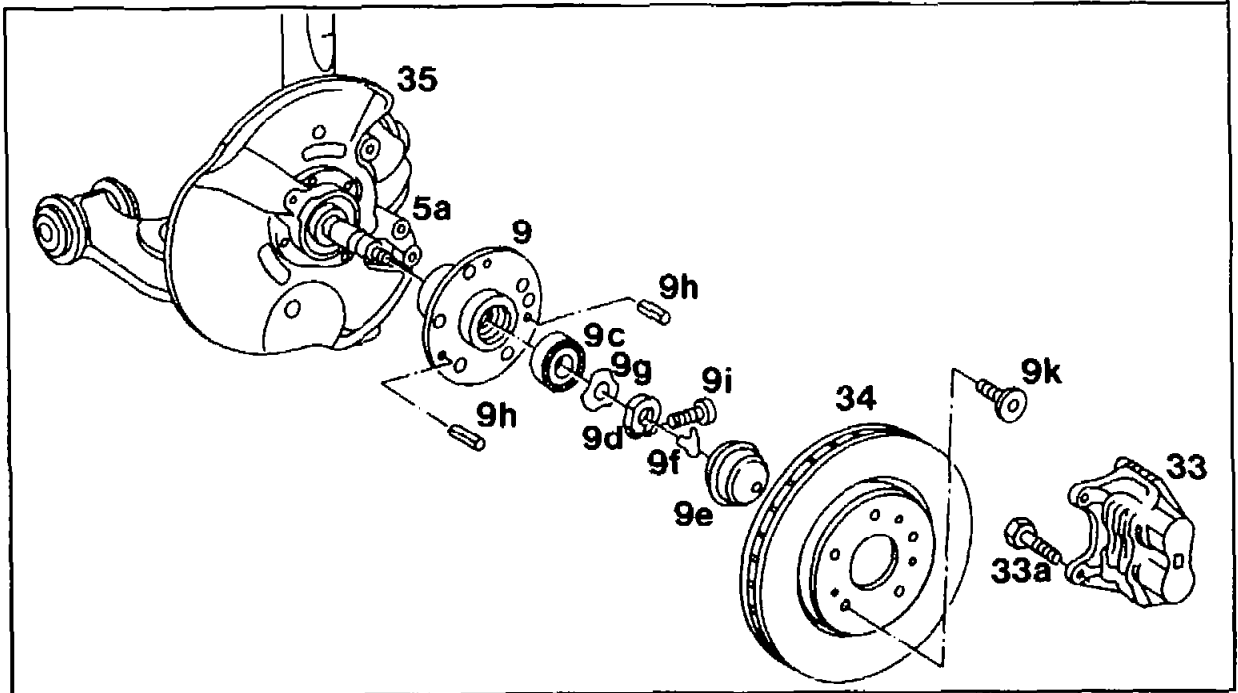

P33-5108-55

Brake disk (34) on front axle	Check, remove, install (42-0200). Replace locking bolt (9k), 10 Nm (step 1).
Hub cap (9e)	Remove with puller 116 589 22 33 00. Fill hub cap up to flared edge with approx. 15 g of high-temperature roller bearing grease and drive on with drift 124 589 00 15 00 (step 2).
On vehicles up to 10/92	
Contact spring (9f)	Remove, install (step 3).
Hexagon socket bolt (9i)	Slacken, tighten to 12 Nm. Unscrew clamping nut (9d). On vehicles up to 10/92 remove washer (9g) (step 4). When installing, adjust wheel bearing play (33-0300).
Front wheel hub (9)	Pull off, push on. Puller 201 589 10 33 00 (step 5).

If inner race of tapered roller bearing is seated very tightly

Pull off using puller 001 589 50 33 00 and collet chuck 201 589 03 34 00. Remove radial sealing ring (step 6).

Brake guard (35)

Check for distortion, corrosion and cracks.

Front wheel hub, tapered roller bearing and radial sealing ring

Check and replace if necessary (33-0320).

Steering knuckle pin (5a)

Check, particularly the bearing seats and contact surface of the radial sealing ring.

Special tools

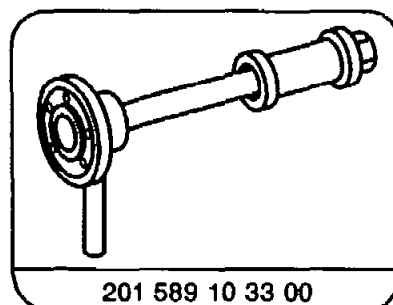
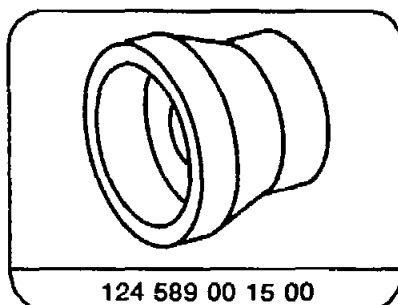
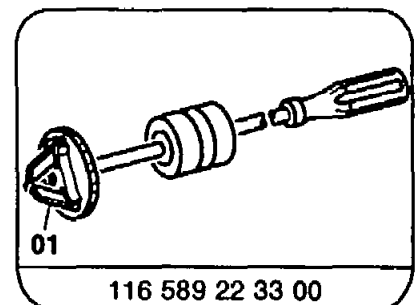
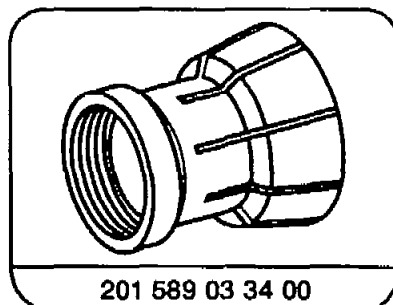
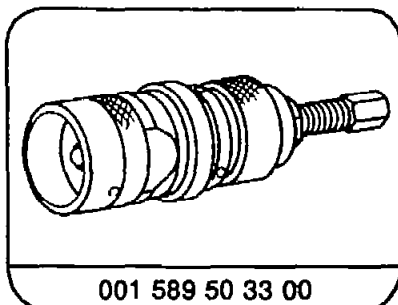

Lubricants

High-temperature roller bearing grease

See MB Specifications for Service Products, sheet Part no. 001 989 23 51/10 (150 g Tube) 265.1

Grease capacity:

In hub cap: capacity approx. 15 g

Removing and installing

1 Check brake disk on front axle and remove (42-0200).

Installation note

Replace locking bolt, 10 Nm.

- 2 Pull hub cap (9e) off wheel hub using puller 116 589 22 33 00.

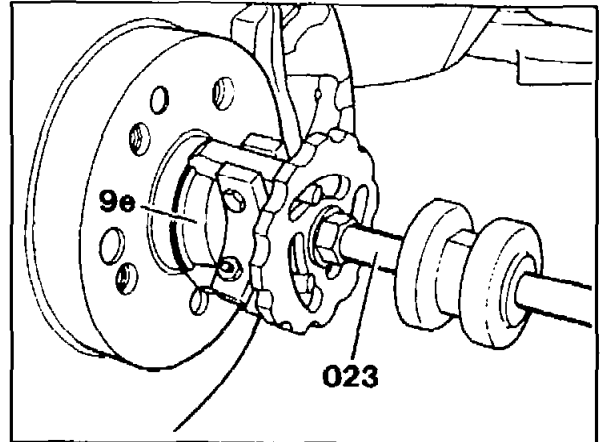

P33-2056-13

Installation note

Fill hub cap up to flared edge (arrow) with approx. 15 g of high-temperature roller bearing grease and drive on with drift 124 589 00 15 00.

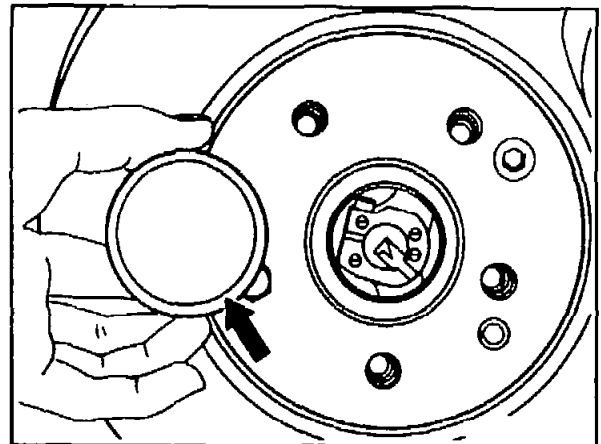

P33-2030-13

Vehicles up to 10/92

- 3 Remove contact spring (arrow) for radio interference suppression.

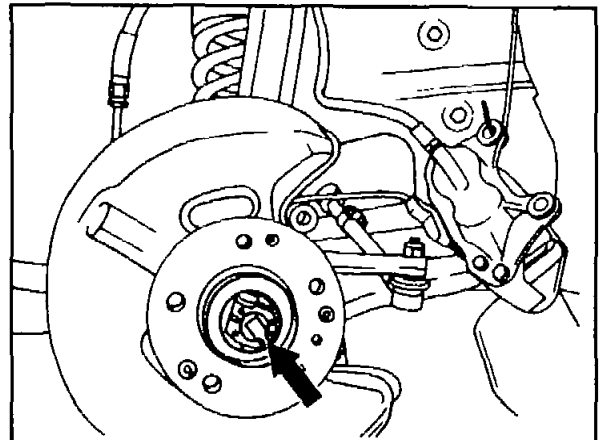

P33-2025-13

- 4 Slacken hexagon socket bolt (9i) and unscrew clamping nut (9d) from steering knuckle pin (5a). On vehicles up to 10/92, remove washer.

Installation note

Adjust wheel bearing play (33-0300), tightening torque of hexagon socket bolt (9i) 12 Nm.

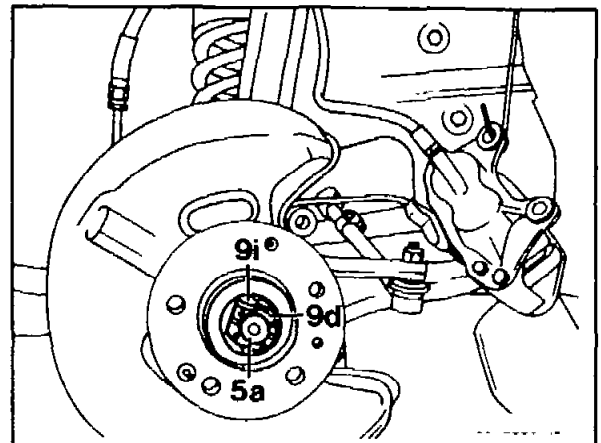

P33-2025-13A

5 If front wheel hub (9) is seated very tightly, use puller (07) 201 589 10 33 00.

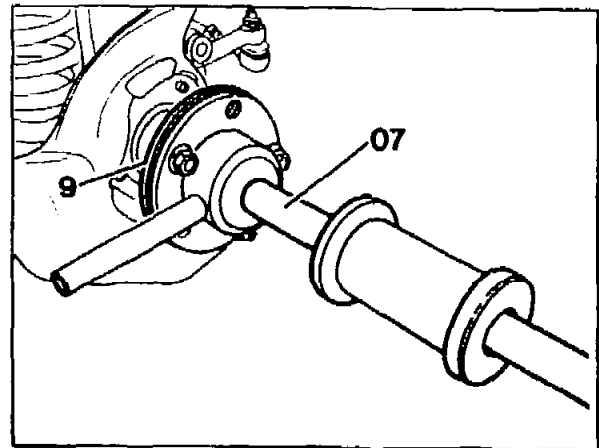

P33-2063-13

6 inner race of tapered roller bearing is seated very tightly, pull off using puller (014) 001 589 50 33 00 and collet chuck (014a) 201 589 03 34 00. Remove radial sealing ring (9a) from steering knuckle (5a).

Installation note

Coat contact surface of radial sealing ring on steering knuckle and pack space between sealing lip and dust lip with high-temperature roller bearing grease.

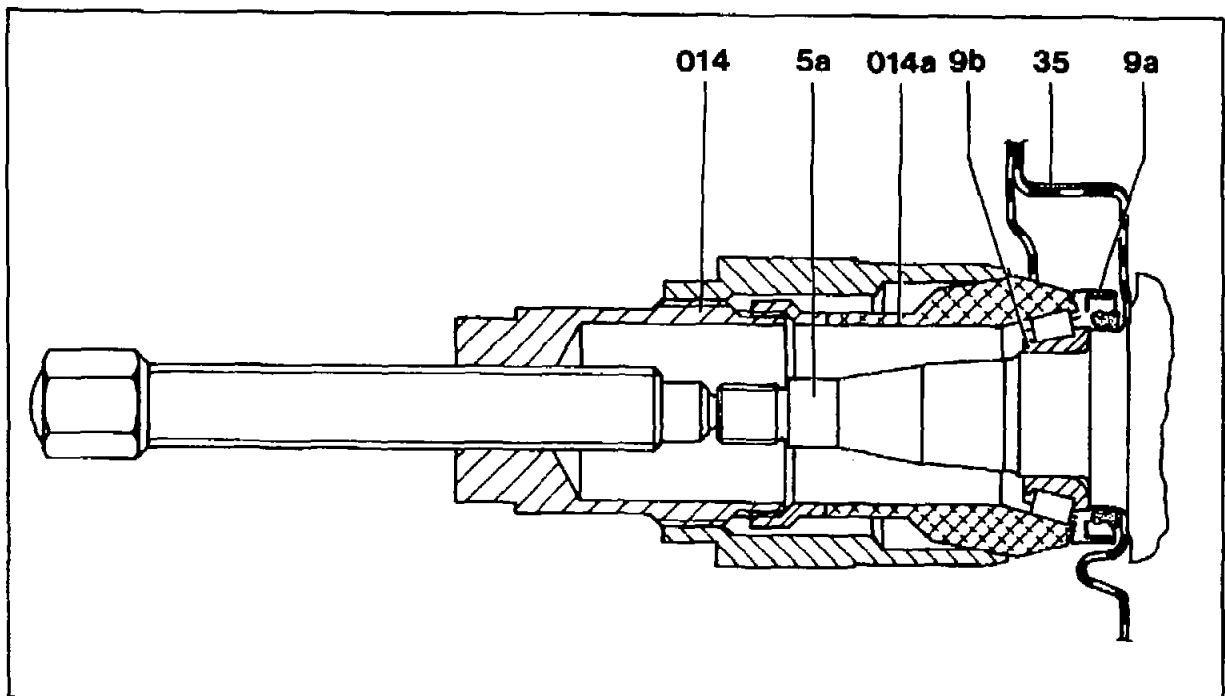

P33-5225-55

7 Check brake guard for distortion and cracks.

8 Dismantle front wheel hub, inspect, repair and reassemble (33-0320).

9 Inspect steering knuckle pin for wear and discoloration (e.g. insufficient grease, severe overheating due to incorrectly adjusted wheel bearing play). Pay particular attention to the bearing seats and the contact surface of the radial sealing ring.

10 Install in the reverse sequence