

## 42-0510 Removal and Installation of parking brake pedal assembly

Preceding work:  
Remove cover below instrument panel (68-0150).  
Remove cover on A-pillar.

Operation no. of operation texts and work units or standard texts  
and flat rates:  
42-5857, 42-5897

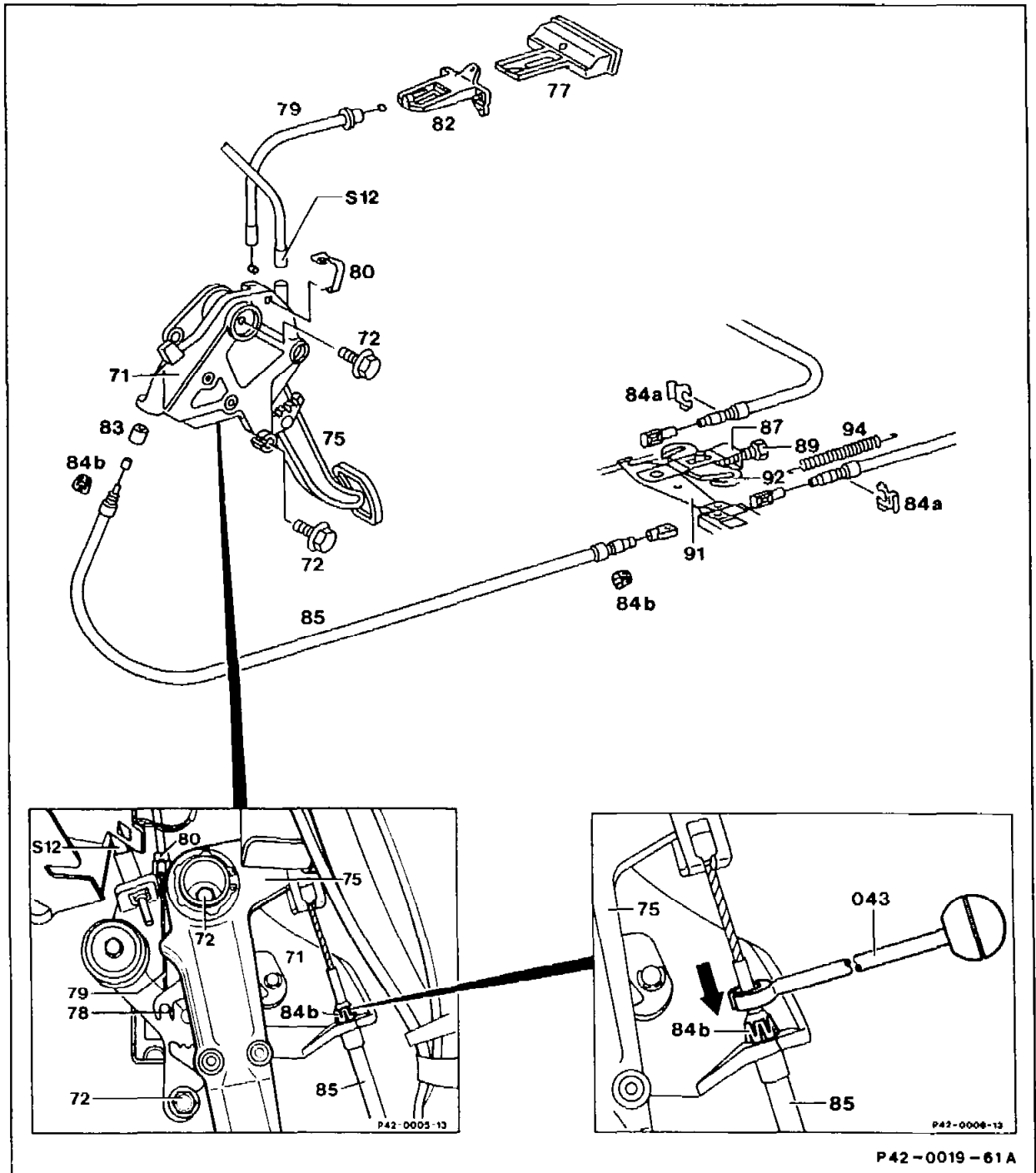

Return spring (94) .....	unhook, hook in.
Adjustment screw (89) .....	screw back on adjustment bracket (87).
Brake cable (85) .....	unhook from pull lug on pedal (75), hook in, press ferrule (84b) together with clip remover (043) 129 589 11 63 00 and pull out control cable. The brake control cable can also be removed by breaking the ferrule. Install new ferrule, part no. 124 427 00 92 in brake control cable slot. When installing ensure that the ferrule is correctly mounted. Observe installation note for spring clip.
Bolts (72) .....	screw out, screw in.
Plug for parking brake switch (S12) .....	disconnect by lifting pedal assembly (71) slightly. Observe Note on switch for the foot-operated parking brake indicator (S12).
Clip (80) .....	remove, install.
Release cable (79) .....	unhook at release handle (77) first, then at guide (82), hook in.
Pedal assembly (71) .....	remove, install.
Parking brake .....	adjust after installing pedal assembly (71) (42-0540).

**Note**

Since 12/89, a foot-operated parking brake with modified ratched segment (18 notches instead of 13 notches previously) has been installed since 1.12.89. The release handle and release cable have been adapted to the modified installation dimensions. Only the new version is available as a replacement part, i.e. when the foot-operated parking brake is replaced on vehicles up to 11/89 it is also necessary to replace the release handle and cable.

## Special tool

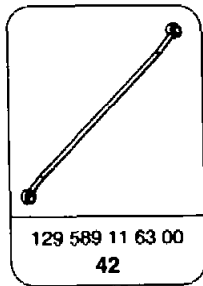

### Note on switch for the foot-operated parking brake indicator

Since 05/87 the switch for the foot-operated parking brake indicator is installed in the pedal assembly support from **below** (version B) (previously from above). The switch mount in the bracket is equipped with two locking lugs positioned in such a manner that installation of the switch from **above** (version A) is no longer possible.

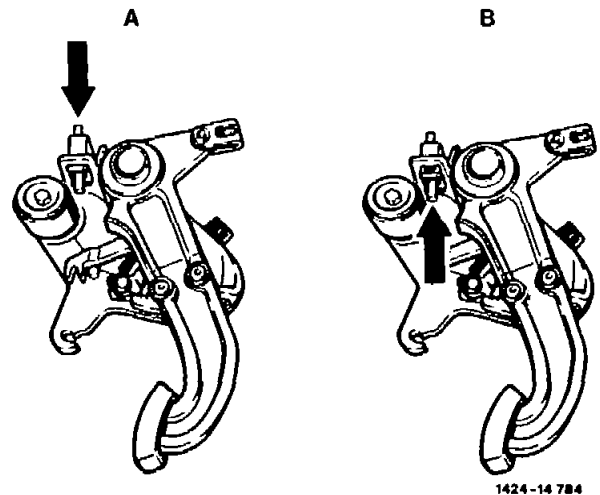

### Note on spring clip

Up to 05/88, model 124 is still equipped with a brake cable (85) which is locked with spring clips instead of ferrules (arrow). The clip remover 129 589 11 63 00 cannot be used on this version.

The spring clip is to be removed/installed using a suitable screwdriver.

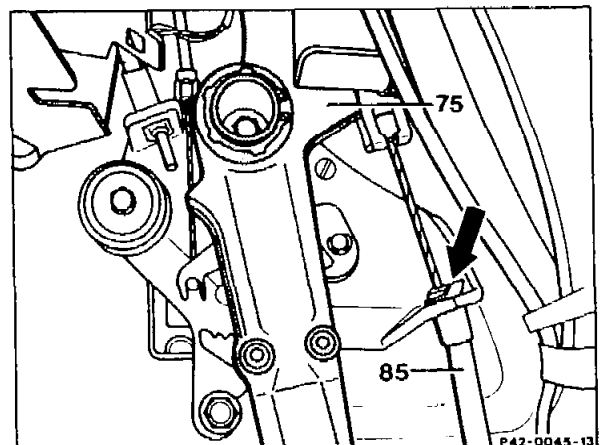

75 Pedal  
85 Brake cable