

42-0515 Removal and installation of hand brake lever for parking brake

Preceding work:
Remove bottom section of center console (68-200).

Operation no. of operation texts and work units or standard texts
and flat rates
42-5859

Model 201

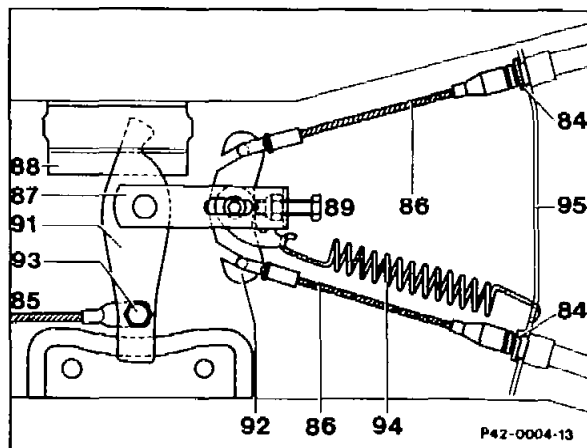
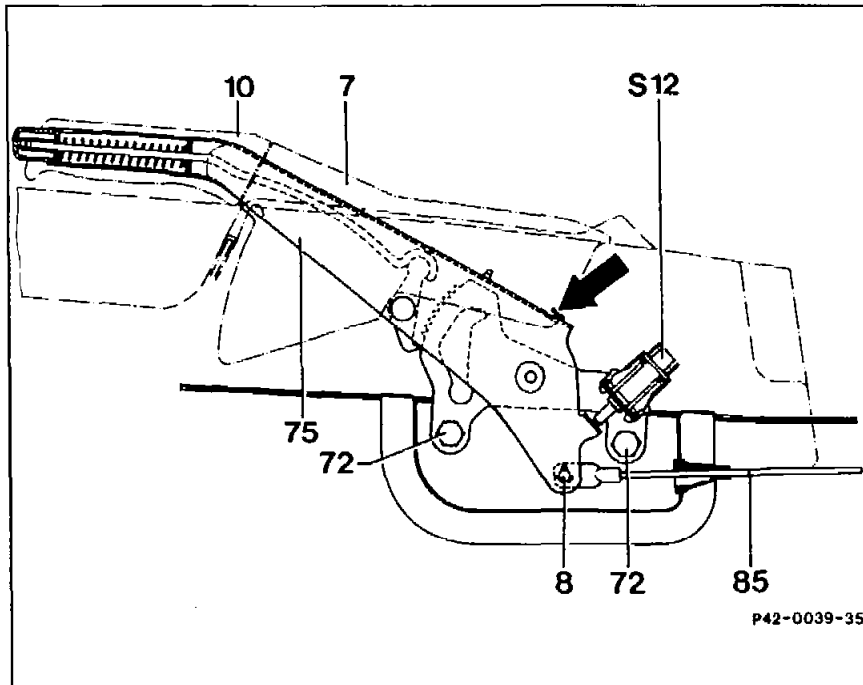

Return spring (94)	unhook on control cable swivel (92), hook in.
Handle (10)	cut off at side and pull off lever (75). Install new handle (10) by driving into lever against stop with stop-made tool. Always install handle in dry condition (without lubricant).
Cover (7)	remove from lever (75). Check whether hook (arrow) on lever (75) is broken off, replace lever, if required. When installing ensure that the cover (7) engages on the hook and cannot be lifted manually at the rear.
Switch for parking brake indicator (S12)	remove, install.
Bolts (72)	loosen and remove lever (72).
Collar pin (8)	remove and remove brake control cable (85). When installing ensure that collar pin is secured properly with collar pin.
Parking brake	adjust (42-0540).

Note

Since 02/87, levers with a ratched segment with 12 teeth and modified handle (10) have been installed as a rule. Vehicles with the lever from production prior to 02/87 can be equipped with the 2nd version.

Shop-made tool

Fabricate installation tool according to drawing.

Materials: light-alloy metal, plastic or hard wood.

