

43-0023 Testing check valve

Preceding work:
Check brake system for leakage using pressure tester
(42-0015).

Operation no. of operation texts and work units or standard texts
and flat rates:
43-1051

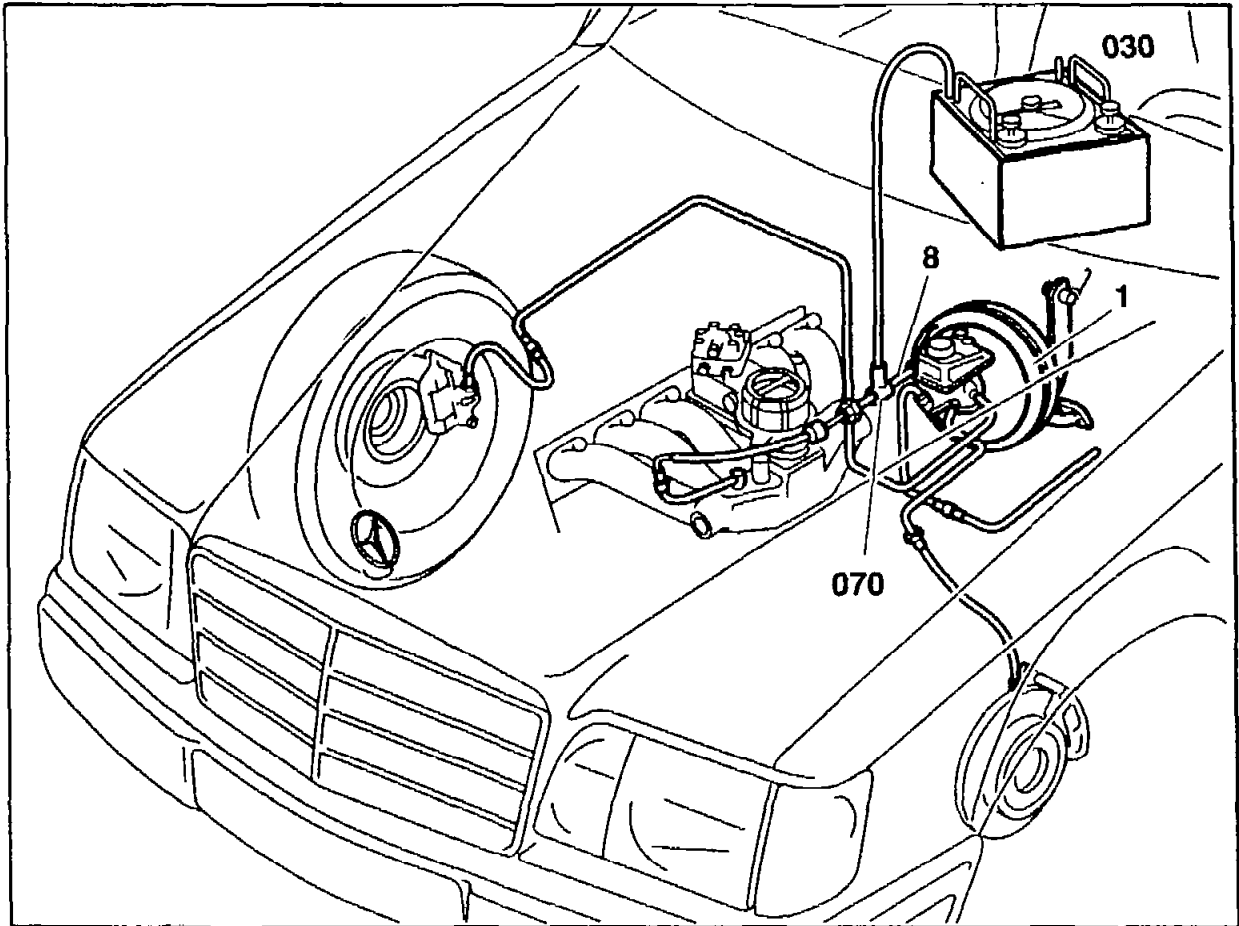

P42-5322-57

Vacuum line (8)	unscrew at brake booster (1), screw on, 30 Nm.
Test connection (070)	screw on between brake booster (1) and vacuum line (8), unscrew. Test connection (070) shop-made.
Tester (030) 201 589 13 21 00	connect to test connection (070), disconnect.

Check valve

check for leakage. For this purpose allow engine to run and create vacuum of 0.75 – 0.8 bar by depressing accelerator and releasing suddenly. A vacuum higher than 0.8 bar can be built up by actuating the brake pedal. Then shut off engine. The vacuum should not decrease by more than 0.2 bars within 30 seconds. If a higher vacuum loss is measured, replace check valve together with vacuum line. Repeat leakage test. If the leakage is still as high as previously, the screwed connections may be damaged or the brake booster may be leaking. Where appropriate, check brake booster (43-0325).

Special tool

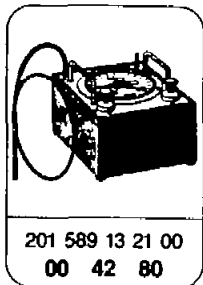

Shop-made tool

Fabricate test connection according to drawing (parts 1, 3, 4, 5 and 6 are brazed together).

