

43-0350 Removal and installation of brake booster

Preceding work:

Remove stepped tandem master brake cylinder (42-0310).

Remove cover below instrument panel (88-0150).

Vehicles with ASP:

Remove pressurizing pump (M15) (42-0863).

Operation no. of operation texts and work units or standard texts and flat rates:

43-1032, 43-1033, 43-1034

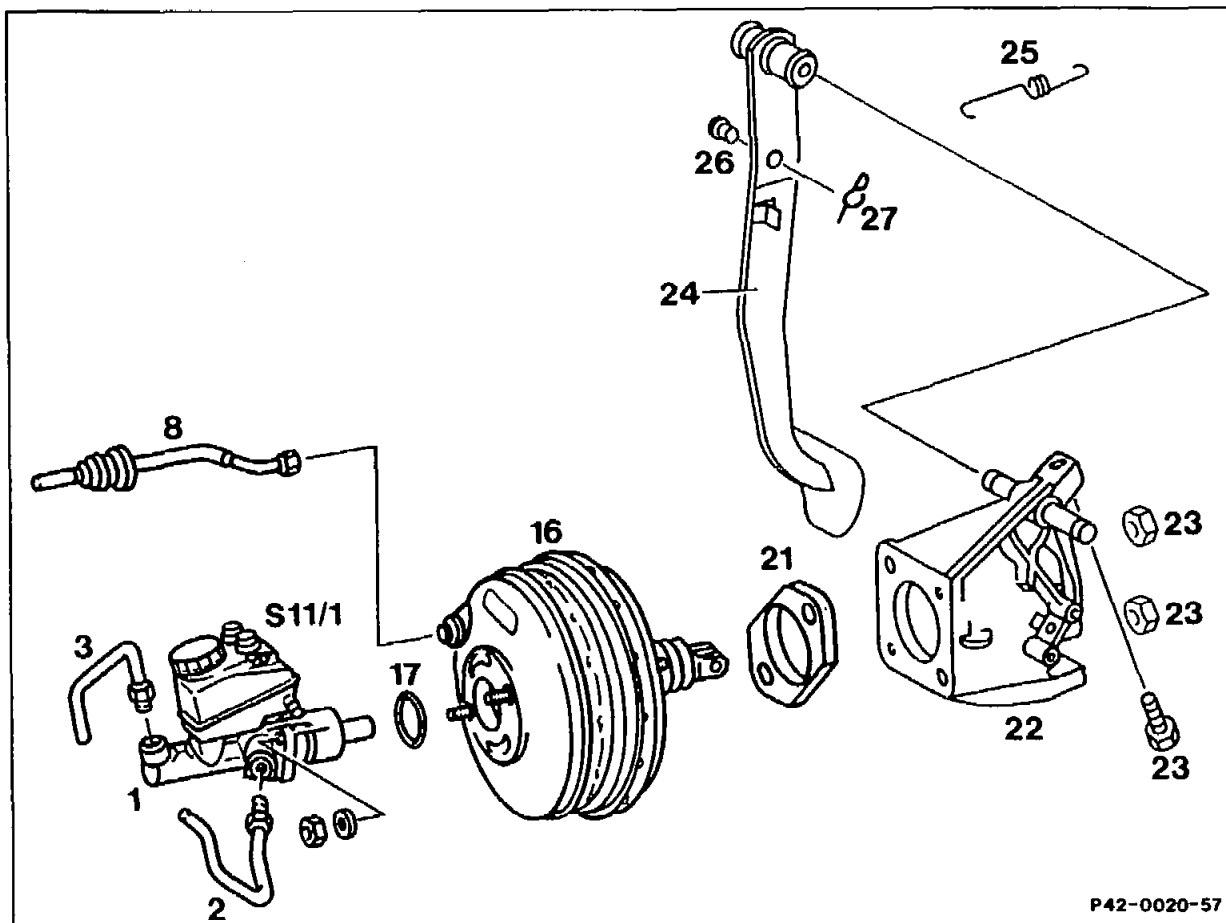

Vacuum line (8)	unscrew from brake booster (16), screw on, 30 Nm.
Brake pedal return spring (25)	Unhook, hook in.
Retainer (27)	pull out of pin (26), install.
Pin (26)	remove from pedal (24), install.
Nuts (23) or bolt	unscrew from bracket (22) on front end, screw on, 15 Nm.
Brake booster (16)	remove, install. The control housing of the brake booster (16) is made of plastic and can break if not treated with care. Test check valve (43-0023).

Joint seal (21)



Check brake booster (16) to see if any brake fluid has entered.

check for damage and proper seating, replace if required.



If brake fluid loss cannot be detected externally, check whether brake fluid has entered the brake booster through a leaky secondary seal in the tandem master brake cylinder. If so proceed as follows:

1. Evacuate brake fluid with installed brake booster.
2. If more than 100 cm³ of brake fluid is present in the brake booster, replace brake booster.

Note

The rolling diaphragm in the brake booster is resistant to brake fluid, but not the reaction disc and the poppet valve in the control unit. For this reason evacuate brake fluid only with brake booster installed. When the brake booster is installed and less than 100 cm³ of brake fluid is present, it is not possible for brake fluid to reach the reaction disc or poppet valve.

Note on vehicles with shift lock

When replacing brake booster it is necessary to readjust the control cable on these vehicles. See "Automatic transmission 722.3" 27-0740 section "C" for adjustment.

