

46-0236 Removing and installing steering shaft/bearing cover, replacing radial seal ring

Preceding work:

Removing and installing steering gear (46-3400).

Removing and installing bearing cover/pitman arm shaft (46-0232).

Removing and installing play compensator (46-0235).

A. Steering shaft/bearing cover with locking ring (up to 10/87)

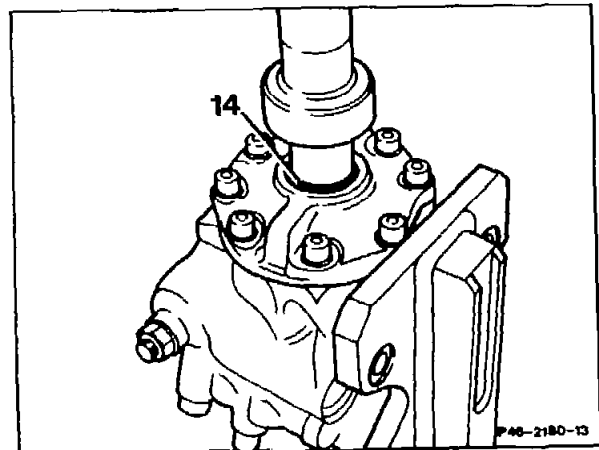
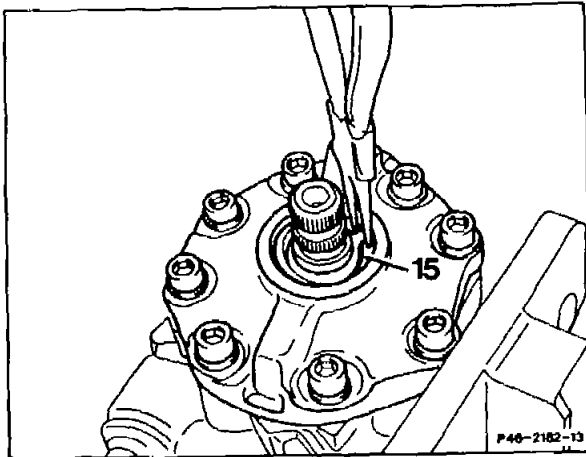

Steering gear (1)	attach to assembly support 140 589 00 59 00 with two bolts and clamp in vise (number 1).
Locking ring (15)	remove from bearing cover/steering shaft. When inserting locking ring, ensure correct seating.
Radial seal ring (14)	press out of the steering shaft/bearing cover with suitable screwdriver. Press in new seal with mandrel 201 589 06 15 00 and coat sealing lip with multipurpose grease.

Special tools

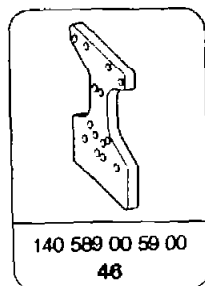
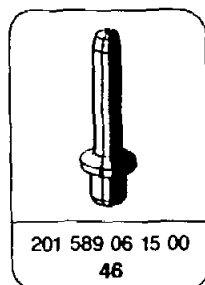

B. Bearing cover/steering shaft with collar (as of 10/87)

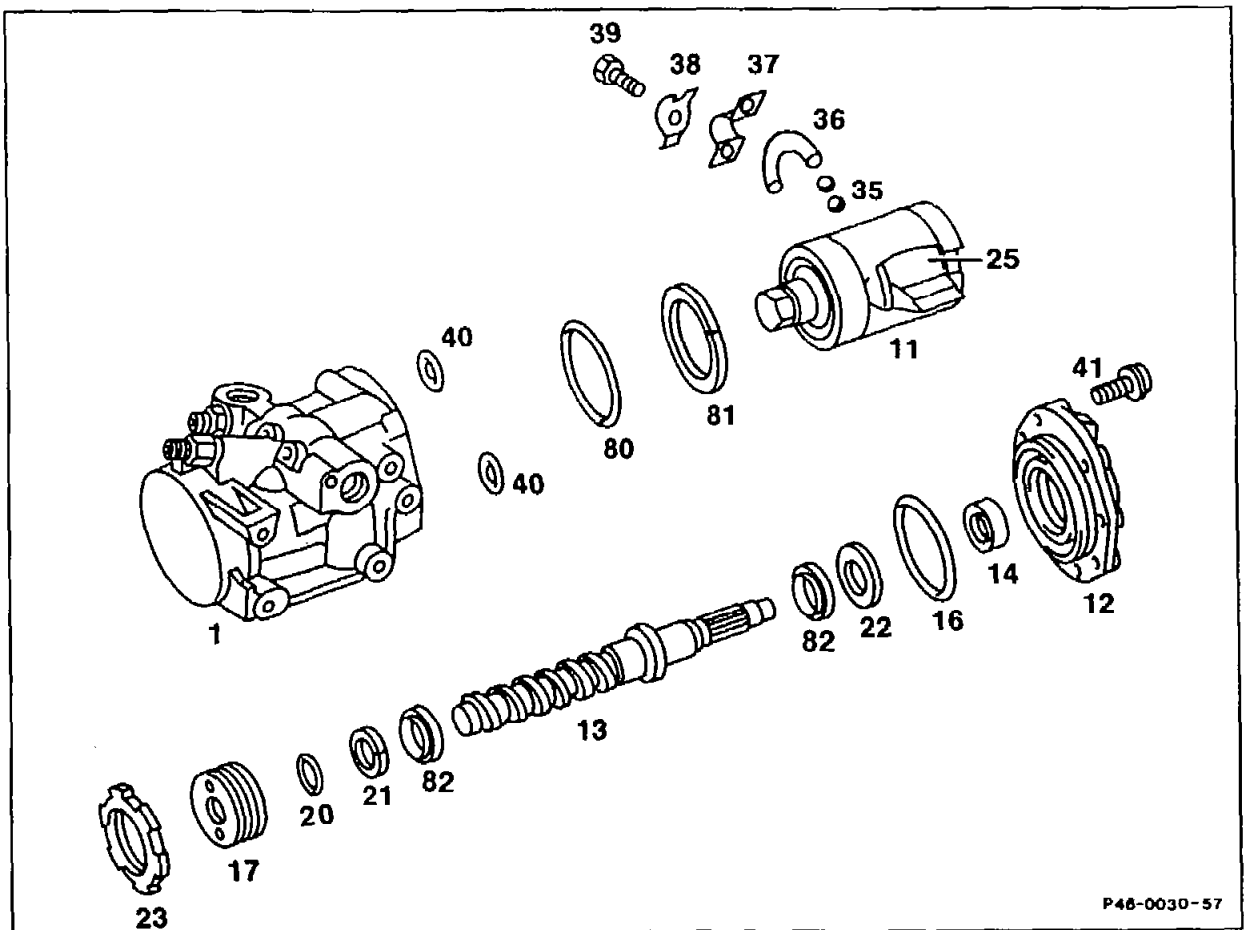

P46-0030-57

- Steering gear (1) attach to assembly support 140 589 00 59 00 with two bolts and clamp in vise (number 1).
- Bolts (41) remove, install, replace, 25–30 Nm (numbers 2, 32).
- Steering shaft (13) rotate counter-clockwise until the steering shaft/bearing cover (12) is raised approx. 10 mm (number 3).

Steering shaft/bearing cover (12) together with steering shaft (13) and power piston (11)	remove from the steering gear housing (number 4). When installing, carefully insert straight edge of steering nut (25) into control valve (number 31).
Power piston (11)	carefully clamp in a vise with aluminum protective jaws (number 5).
Friction torque of recirculating ball assembly	measure with friction torquemeter 001 589 81 21 00 and wrench insert 123 589 00 80 00 and note value (number 6). After assembling recirculating ball assembly, the measured value should again be achieved (number 28).
Bolts (39)	remove, screw in, 12–15 Nm, take off guard plate (38) and retaining clip (37) (numbers 7, 27).
Ball guide halves (36)	take off. When installing, insert 6 or 7 (model 140) balls (35) with grease into the ball guide halves. Insert ball guide halves into steering nut (numbers 7, 25, 26).
Steering shaft (13)	unscrew from steering nut (25). Ensure that none of the 23 or 24 balls (model 140) is lost (number 8). When installing steering shaft, introduce balls into recirculating ball assembly by slowly turning (number 24).
Bearing cover/steering shaft (12)	after removing O-ring (16), screw into the retaining device 140 589 04 31 00 or 210 589 05 31 00 (number 9).
Teflon ring (81) and O-ring (80)	check in steering gear housing, replace, if necessary (number 10).

Inner slotted round nut (23), bearing insert (17),
needle bearing (82) and washer (22) remove (numbers 11–13).

Pronged wrench 140 589 03 07 00

Pin wrench 140 589 04 07 00

When installing, set friction torque of steering shaft in steering shaft/bearing cover, tightening torque of inner slotted round nut 280–320 Nm (numbers 17–20).

Radial seal ring (14) remove, press in, replace, use mandrel
140 589 07 15 00 (numbers 14 and 15).

Bearing insert (17) and Teflon ring (20) examine for signs of damage and wear, replace if necessary (number 16).

O-rings (40) replace (number 29).

Special tool

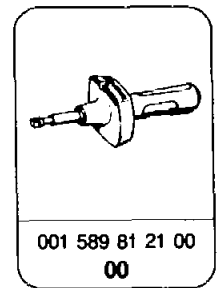
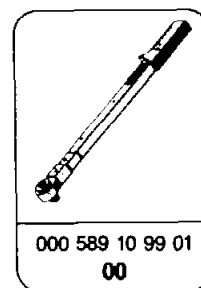
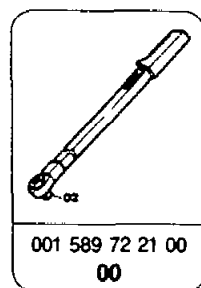
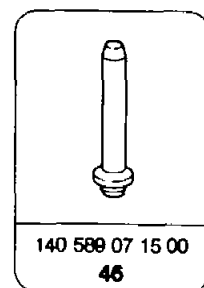
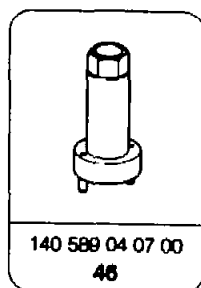
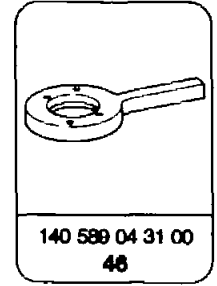
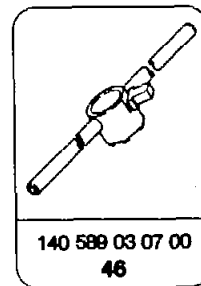
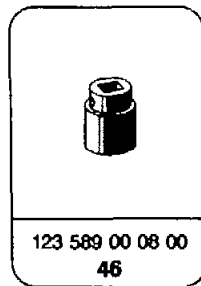
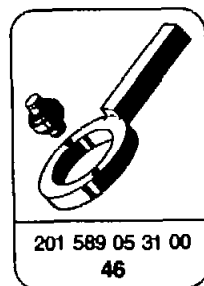
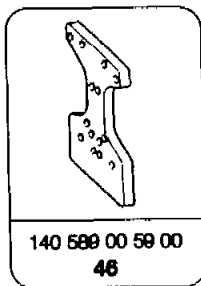



Pay attention to "Important notes regarding repair of steering gear" (Operation no. 46-0230).

Disassembling and assembling

1 Attach steering gear to assembly support 140 589 00 59 00 with two bolts and clamp in vise.

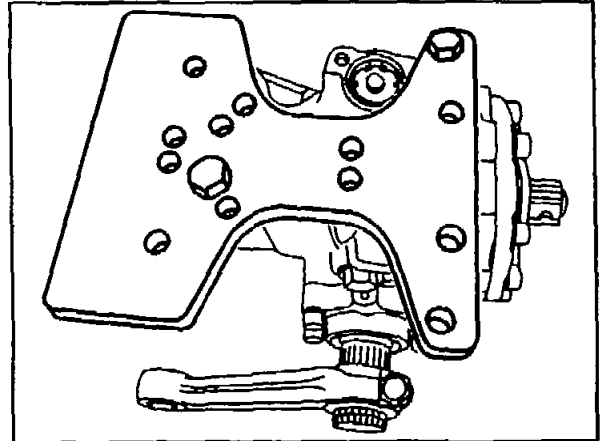

P46-5480-13

2 Unscrew self-locking hexagon socket bolts (41) for attaching steering shaft/bearing cover (12).

3 Rotate steering shaft (13) counter-clockwise until the steering shaft/bearing cover (12) is pressed approx. 10 mm out of the steering gear housing.

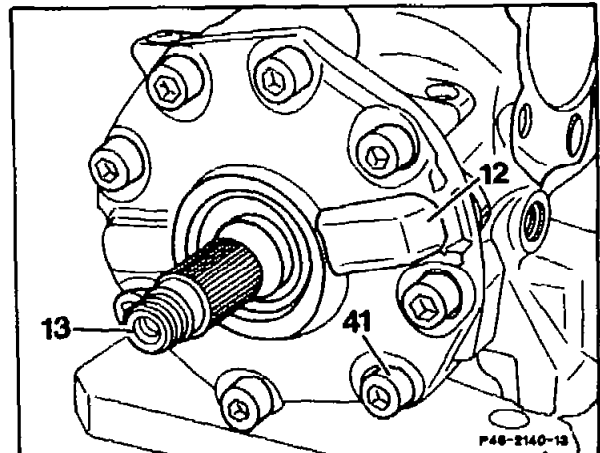

P46-2140-13



Do not rotate steering shaft too far otherwise the balls will drop out of the recirculating ball assembly.

4 Remove steering shaft/bearing cover together with steering shaft and power piston from the steering gear housing.

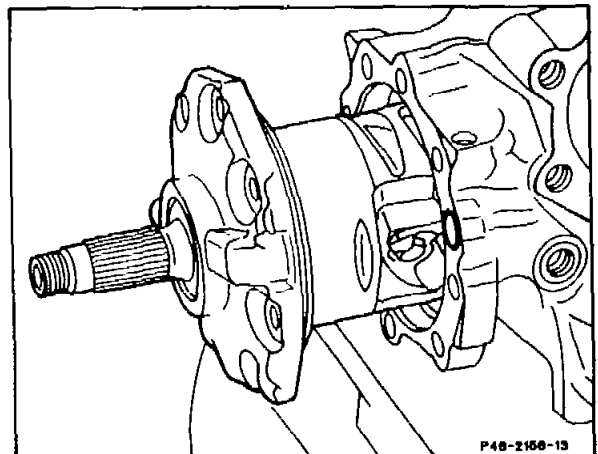

P46-2158-13

5 Carefully clamp power piston (11) with bearing cover/steering shaft and steering shaft in vise with aluminum protective jaws.



Ensure complete cleanliness.

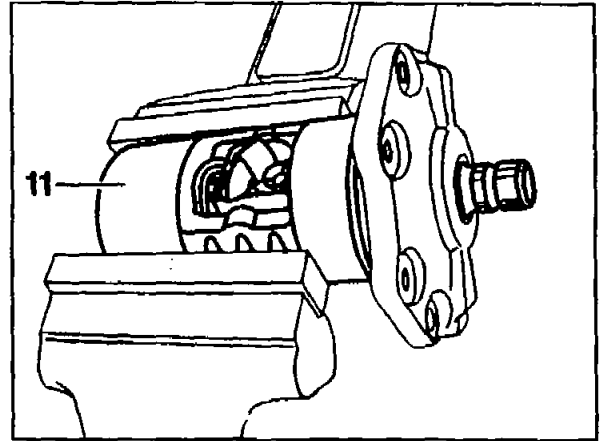

P40-5479-13

6 Measure friction torque of the recirculating ball assembly. When measuring friction torque of the steering nut to the steering shaft, use torque screwdriver 001.589.81.21.00 in combination with wrench insert 123.589.00.08.00. Whilst steadying the steering shaft/bearing cover (12) turn steering shaft anticlockwise and clockwise several times, read off and note friction value. The friction torque must be 5–50 Ncm.



Do not turn steering shaft too far to the left otherwise the balls will drop out of the recirculating ball assembly.

If any sticking or play is detected in the recirculating ball assembly when rotating, the steering gear should be replaced completely.

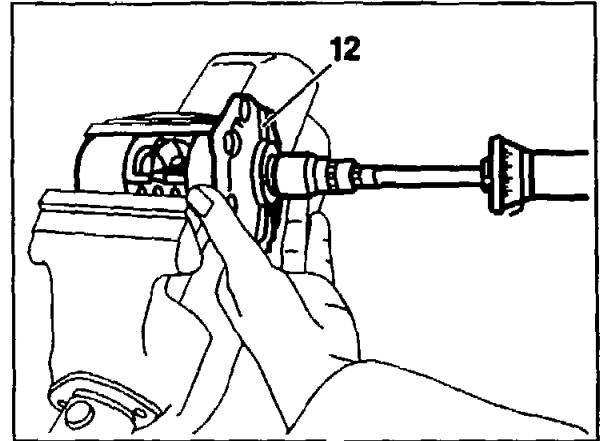

P46-5479-13

7 Bend up locking plate (38), unscrew hexagon bolts (39) and take off locking plate (38), retaining clip (37) and both ball guide halves (36) together with balls.

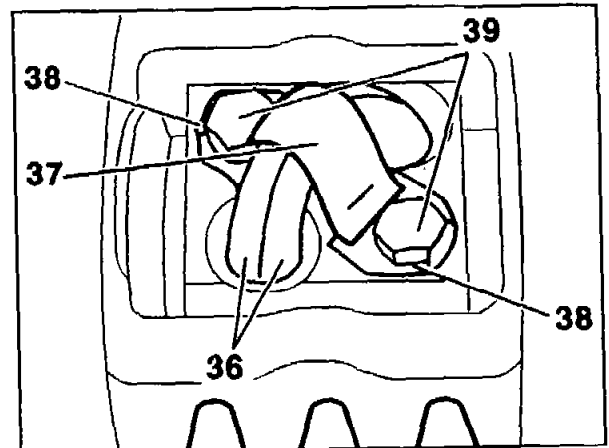

P46-5486-13

8 Unscrew steering shaft (13) out of the steering nut (25) and carefully remove the balls with a bar magnet or similar if required. Ensure that none of the total of 23 balls, or 24 (model 140) are lost.



The balls are not available as a part. The power piston together with steering nut (25) must not be disassembled. If scoring is detected on the power piston, indentations on steering shaft or sticking steering nut, the steering gear should be replaced.

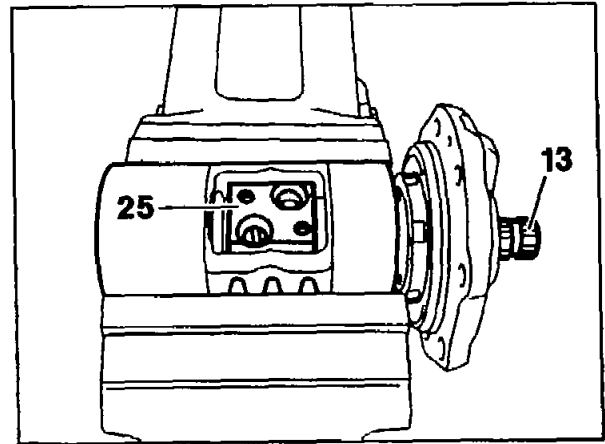

P46-5488-13

9 Take O-ring (16) off the steering shaft/bearing cover. Insert steering shaft/bearing cover in the retaining device 140 589 04 31 00 or 201 589 05 31 00, and then tighten with two bolts.

Note

On steering gears fitted to models 124.034/036 and 140, remove gasket and check for damage, replace if necessary.

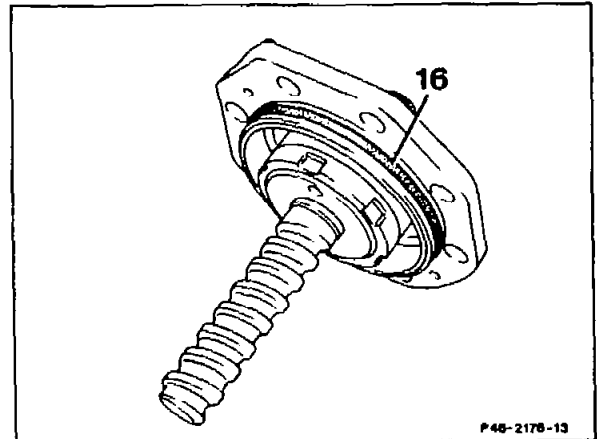

P46-2178-13

10 Examine Teflon ring (81) and O-ring (80) in the steering housing, replace, if necessary.

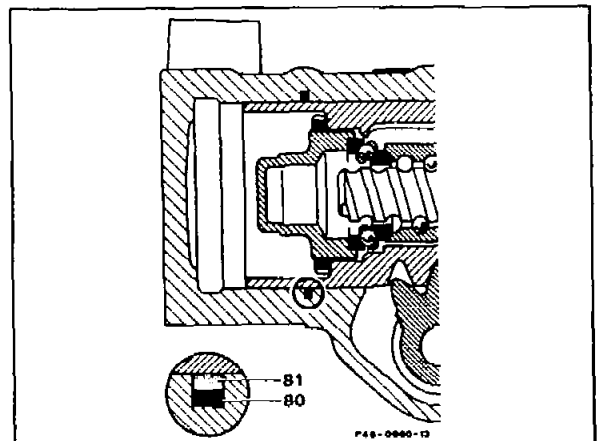

P46-0960-13

11 Unscrew inner slotted round nut (23) from the bearing insert with the pronged wrench 140 589 03 07 00.

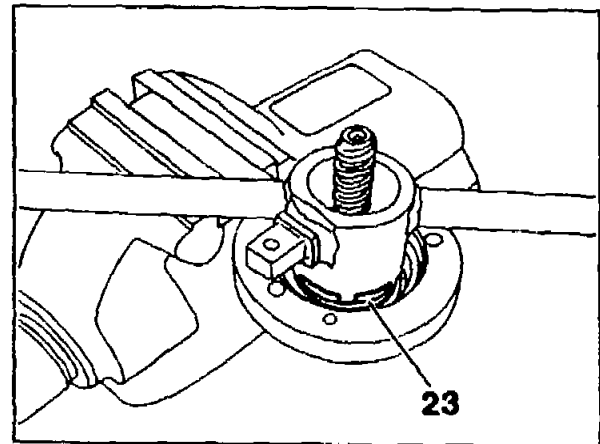

12 Unscrew bearing insert (17) from the steering shaft/bearing cover (12) with the pin wrench 140 589 04 07 00.

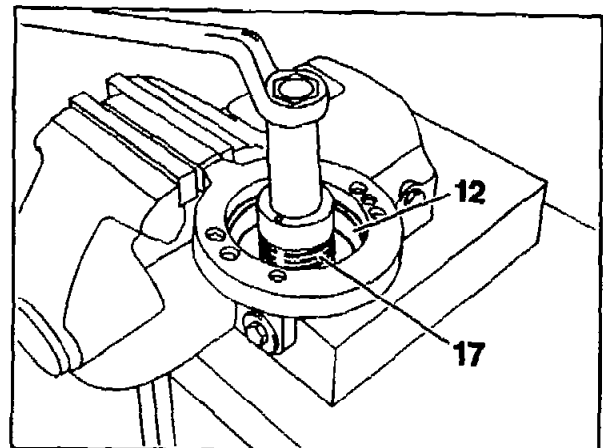

13 Withdraw steering shaft (13) from the steering shaft/bearing cover; take the needle bearings (82) and the disc (22) off the steering shaft. Examine steering shaft, balls, needle bearings and bearing surfaces for signs of damage and wear.

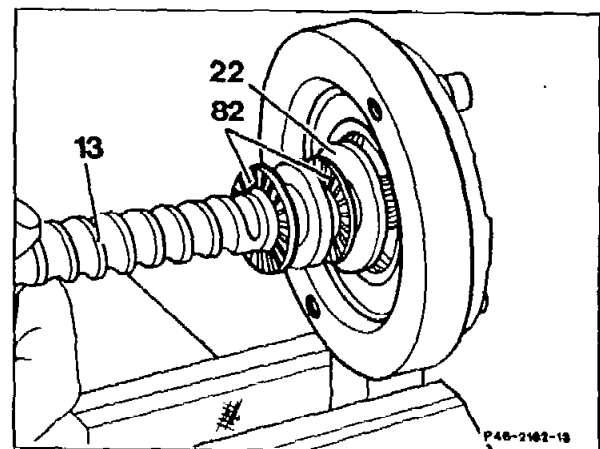

14 Press radial seal ring out of the steering shaft/bearing cover (12) with a suitable mandrel.

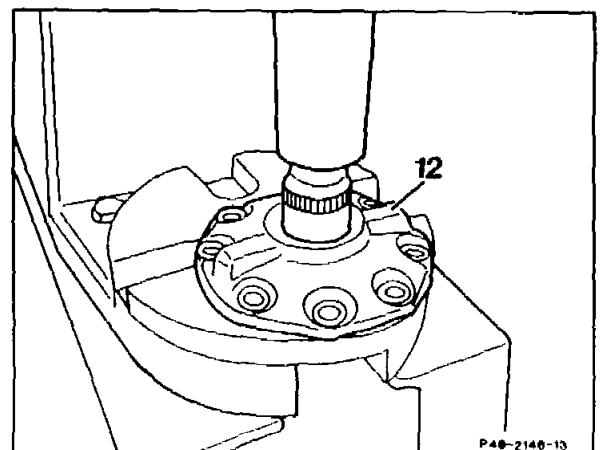

15 Press new radial seal ring (14) into the steering shaft/bearing cover (12) as far as the collar with the mandrel (035) 140 589 07 15 00. Coat the sealing lip with multi-purpose grease.

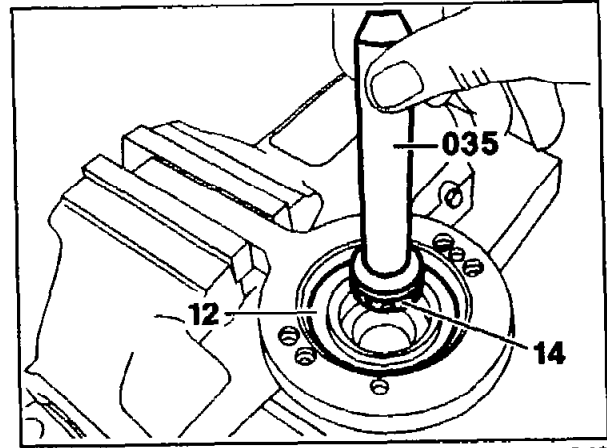

P46-5490-13

16 Check Teflon ring (20) and replace if necessary. Check needle sleeve (18) for wear. If the needle sleeve is damaged, replace bearing insert (17) complete.

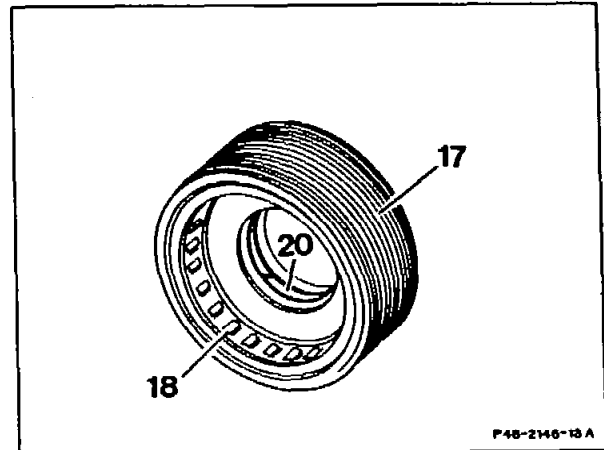

P46-2146-13 A

17 Push washer (22) and steering shaft (13) with the two needle bearings (82) into the bearing cover/steering shaft.

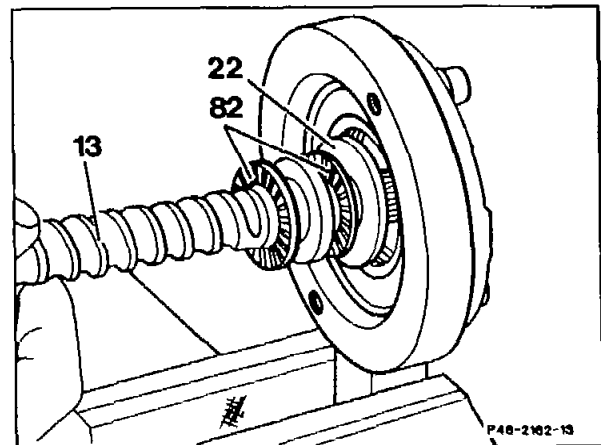

P46-2162-13

18 Screw bearing insert (17) into the bearing cover/steering shaft (12) and tighten slightly. Screw on inner slotted round nut (23) onto the bearing insert (17).

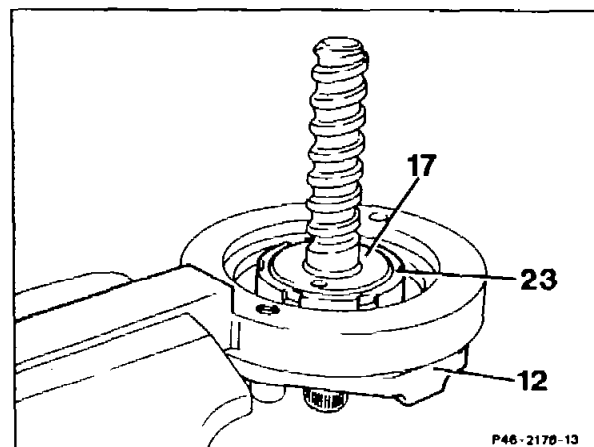

P46-2176-13

19 Measure friction torque of steering shaft in bearing cover/steering shaft.
The friction torque should be 10–15 Ncm, measured with the torque screwdriver 001 589 81 21 00 in conjunction with the socket wrench insert 123 589 00 08 00.

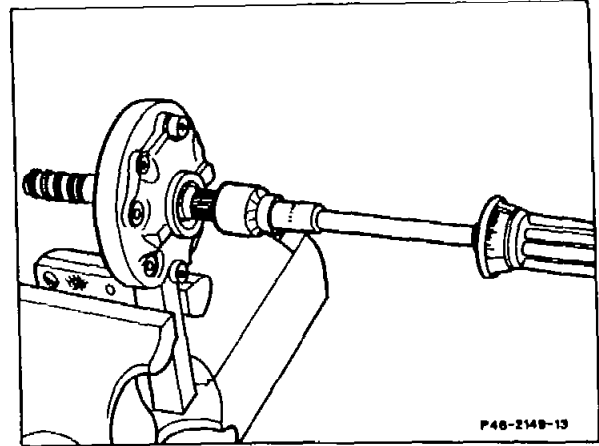

20 Tighten bearing insert with the pin wrench 140 589 04 07 00 until a friction torque of approx. 20 Ncm exists. Tighten inner slotted round nut (23) to 280–320 Ncm with claw wrench 140 589 03 07 00, whilst steadying the pin wrench. Re-check friction torque.

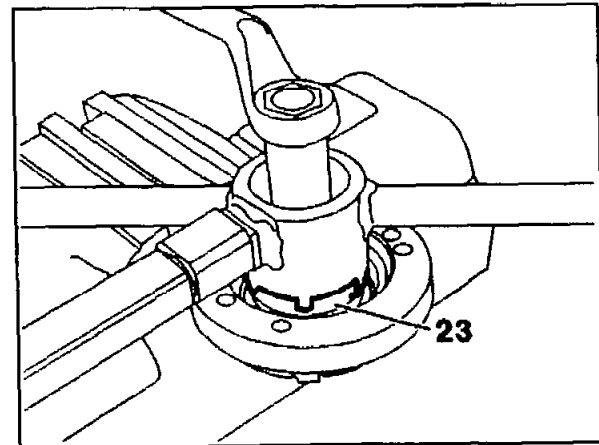

21 Remove steering shaft/bearing cover together with steering shaft from the assembly support and insert new O-ring (16).

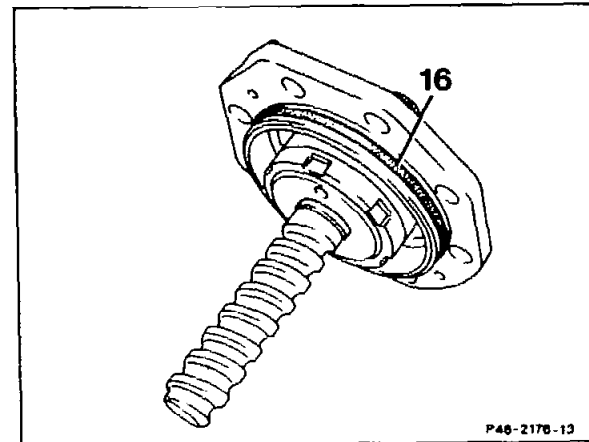

Note

On steering gears fitted to models 124.034/036 and 140, a sealing washer with integrated O-ring (arrow) is used in place of the O-ring.

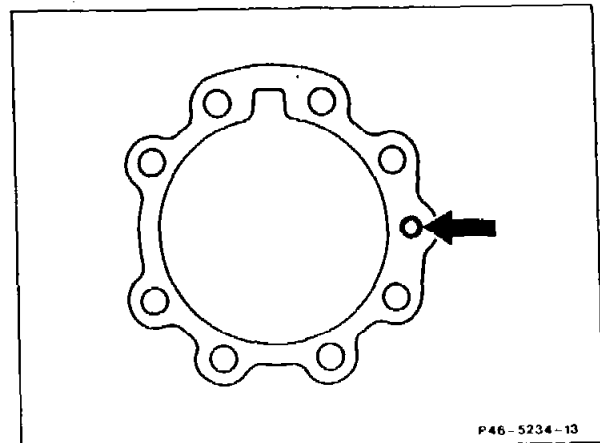

22 Carefully clamp power piston (11) in vise with aluminum protective jaws.



Ensure complete cleanliness.

23 Introduce steering shaft (13) together with steering shaft/bearing cover into the steering nut far enough for a ball track to be fully visible through the first hole in the steering nut (25).

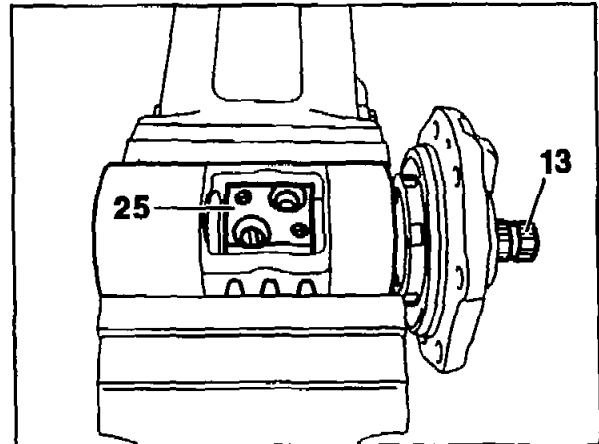

P46-5488-13

24 Insert 17 balls into the ball recirculating assembly while slowly turning the steering shaft clockwise.

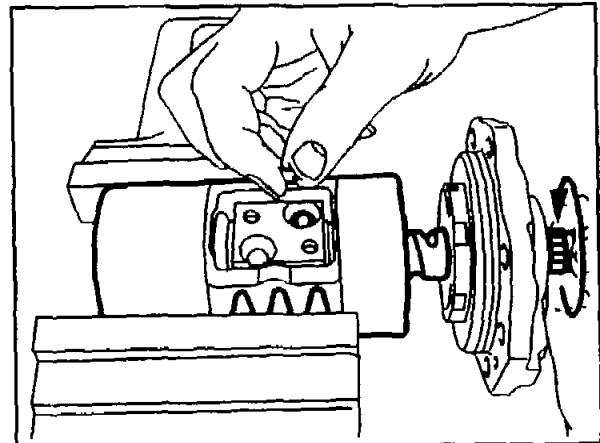

P46-5487-13

25 Pack one ball guide half (36) with grease and insert the remaining 6 balls or 7 (model 140). Place both ball guide halves on top of each other and close the openings with grease.

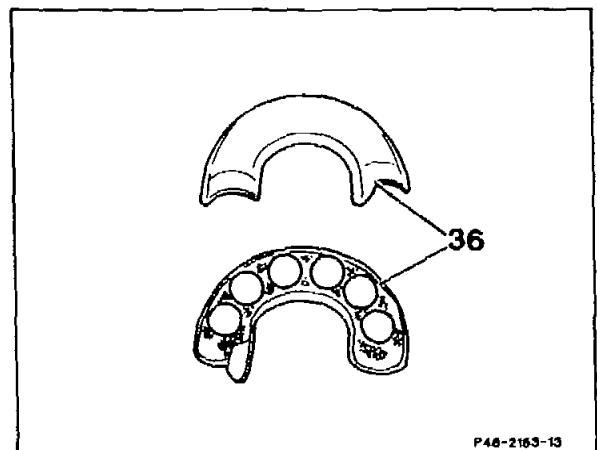

P46-2163-13

26 Insert ball guide halves (36) into the steering nut.

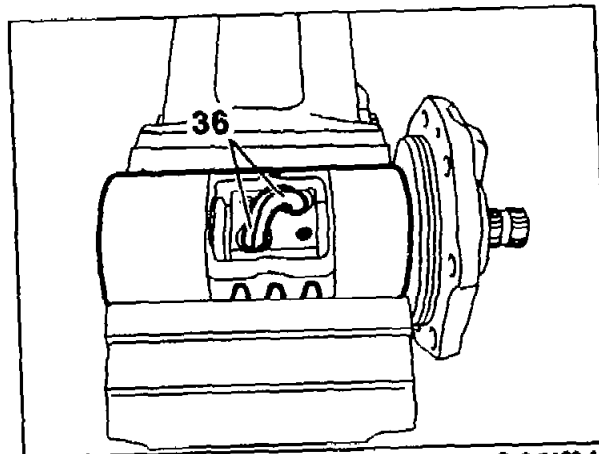

P46-5489-13

27 Fit fixing clip (37) and new locking plates (38) onto the steering nut. Screw in hexagon bolts (39) and tighten to 12–15 Nm.

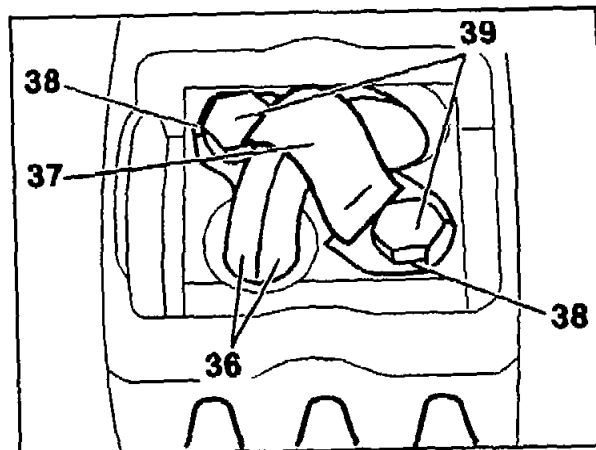

P46-5486-13

28 Measure friction torque of ball circuit. Use torque screwdriver 001 589 81 21 00 and socket wrench insert 123 589 00 08 00 to measure the friction torque of the steering nut to steering shaft. Whilst steadying the steering shaft/bearing cover (12) turn steering shaft anticlockwise and clockwise several times and read off friction value. The friction torque of approximately 5–50 Ncm should not differ from the value established in the initial measurement (number 6).

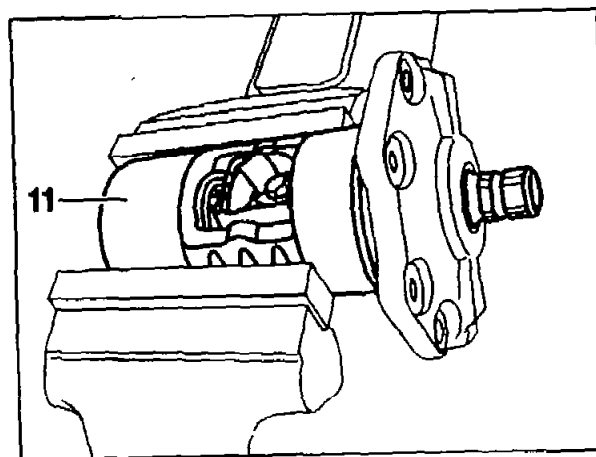

P40-5479-13



Do not turn steering shaft too far anticlockwise, otherwise the balls will fall out of the ball circuit. If, whilst turning the steering, a high spot or play in the ball circuit is found, the complete steering gear must be replaced.

29 Insert new O-rings (40) for the steering shaft/bearing cover into the steering gear housing.

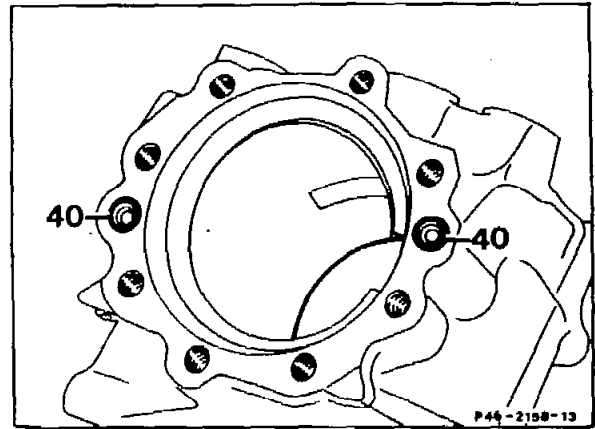

30 For models with steering gears as of 3/89, a restrictor is fitted in the top lube oil passage. Before installing the steering shaft/bearing cover, ensure the passage is clear.

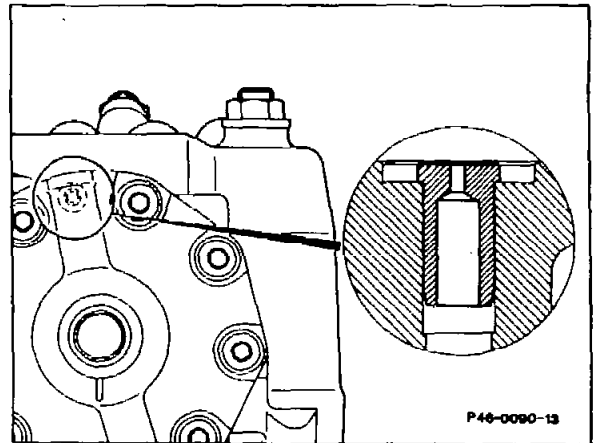

31 Carefully insert power piston complete with steering shaft, steering nut and steering shaft/bearing cover into the control valve or into the steering gear housing. Check that the O-rings are correctly seated.

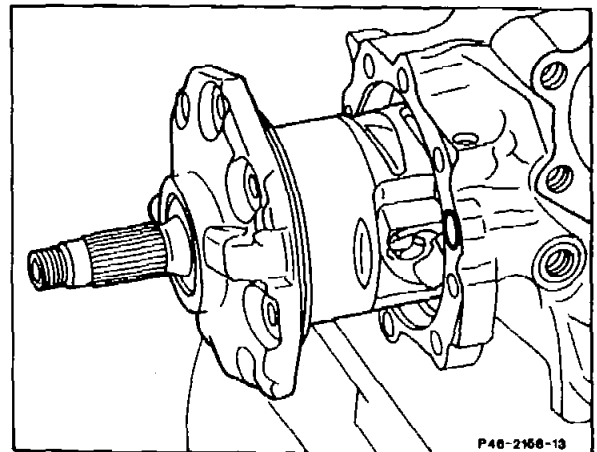

32 Screw in new self-locking hexagon socket bolts (41) and tighten to 25–30 Nm.

33 Install steering shaft/bearing cover (12) together with pitman arm shaft (46-0232).

34 Install play compensator (46-0235).

35 Adjust total friction torque of steering gear (46-0120).

