

80-430 Removing and installing driver door infrared remote control (IFZ) receiver unit (A26/1)

Operation no. of operation texts and work units
or standard texts and flat rates

A. Sedan, station wagon

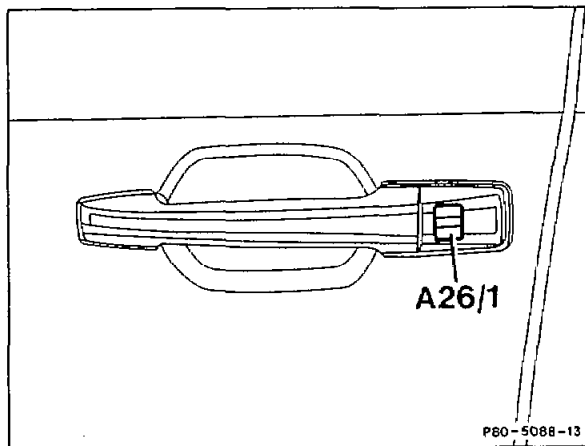
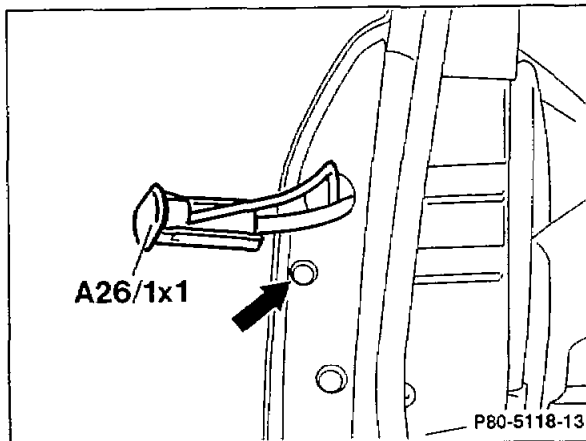

Press off cover (arrow)	unscrew, screw in hexagon socket bolt (3 mm) approx. 4 rotations.
Cover with plug connection, driver door infrared remote control (IFZ) receiver unit (A26/1x1)	remove from door, install.
Plug connection, driver door infrared remote control (IFZ) receiver unit (A26/1x1)	disconnect, contact.
Driver door infrared remote control (IFZ) receiver unit (A26/1)	press out of catch on door panel and remove, install.

B. Coupé, cabriolet

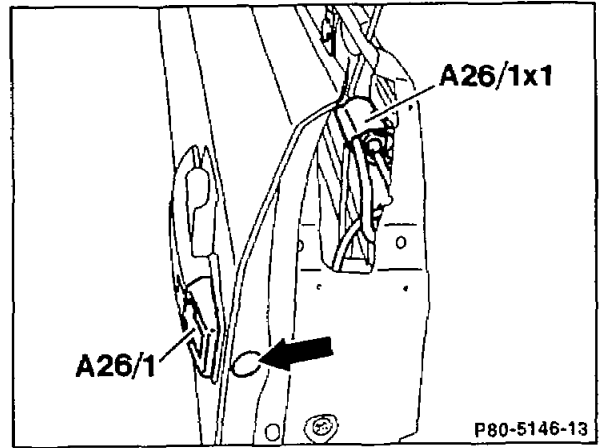
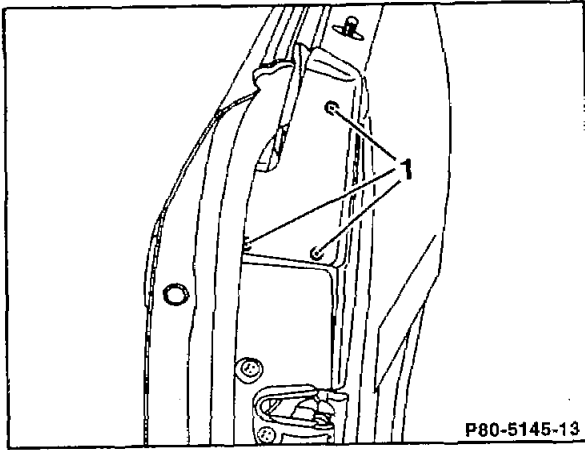

Chrome surround (3 screws, 1)

Press off cover (arrow)

Plug connection, driver door infrared remote control (IFZ) receiver unit (A26/1x1)

Driver door infrared remote control (IFZ) receiver unit (A26/1)

unscrew, screw on.

unscrew, screw in hexagon socket bolt (3 mm) approx. 4 rotations.

disconnect, contact.

press out of catch on door panel and remove, install.



When installing, clip cable of driver door infrared remote control (IFZ) receiver unit (A26/1) into bracket on lock cover.