

82-1130 Adjusting front lighting

Operation no. of operation texts and work units or standard texts
and flat rates:
82-1130

Adjustment table (sizes in cm for test area at 10 m distance from headlamp)

Type of vehicle	The vehicle should be laden as follows for the setting	Setting "e" Main headlamps	in cm Fog lamps
Passenger cars, of which the top edge of the reflectors of the headlamps is not higher than 135 cm above ground level.	With one person or 75 kg on the driver's seat and vehicle otherwise unladen (unladen weight*)	10	10

* The unladen weight is the weight of the vehicle ready for the road with completely filled, installed fuel tanks, including the weight of all equipment carried on board when driving (e. g. spare wheels and tyres, spare parts, tools, vehicle jack, fire extinguisher).

A. Preparations for adjustment

The vehicle should be parked on a level surface for adjusting the headlamps. Even minor unevennesses at the point at which the vehicle is parked may falsify the setting. The specified inflation pressure should be maintained at all the tyres. The vehicle should be laden in accordance with the figures stated in the adjustment table, and then slowly driven onto the parking area in order not to alter the spring setting when applying the brakes.

Adjust the headlamps individually by switching off or covering over the other headlamps. Whenever possible, perform adjustments in an enclosed area and which is fairly dark since the accuracy of the adjustment can be influenced by wind (movement of test surface) and by other light sources. Use a headlamp setting device whenever possible. Closely follow the relevant instructions for the equipment. If no headlamp setting device is available, the headlamps can be set by using an adjustable, flat test surface.

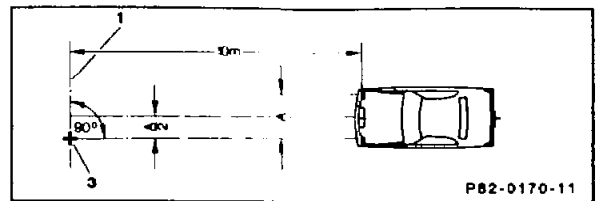

If need be, the test surface can also be drawn on a wall. The wall should be light in colour and be provided with a central mark and a boundary line which is vertical in relation to the longitudinal axes of the vehicle. If the settings shown in the adjustment table are used, the distance between the test surface and the headlamp to be adjusted should be 10 meters.

Test surface (Sizes in cm)

- 1 Test surface
 - 2 Boundary line
 - 3 Central mark
 - 4 Breakpoint
- min. = minimum

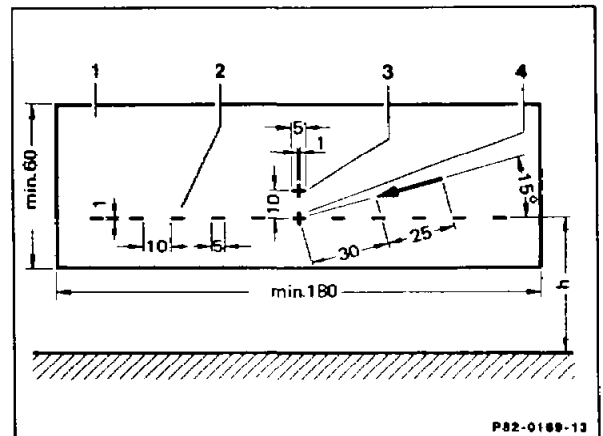

Where the light beam is sharply inclined, e. g. in the case of fog lamps, select the distance of 5 meters; in this case the specified setting should be halved. The central mark of the test surface must be in the plane parallel to the vehicle longitudinal center plane which passes through the center of the headlamp to be adjusted. The boundary line must be set to height h parallel to the vehicle base for each headlamp to be adjusted.

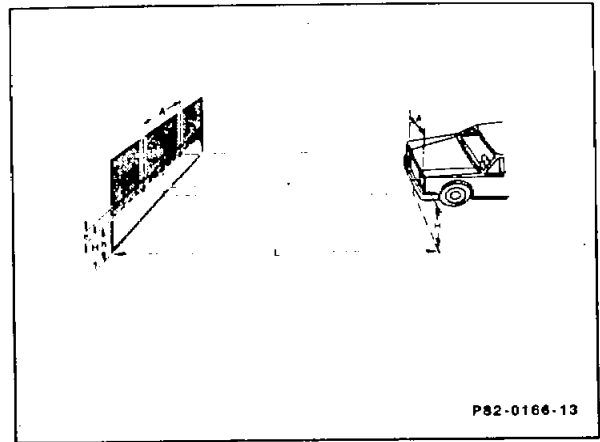

Note for vehicles with headlamp range control

Before setting the headlamps, run engine briefly and build up vacuum by blipping throttle several times. Following this, move regulating switch from "0" to "3" and check whether the headlamps adjust. If the headlamps do not adjust, rectify fault.

Check headlamp setting in the basic position "0" of the regulating switch and adjust to correct setting, if necessary.

Models with self-levelling suspension

After the car is laden properly, the engine of models with self-levelling suspension on the rear axle must be run at a moderate speed for about 30 seconds. Move car forward and backward in order to properly adjust the axle.

B. Main headlamps

The main headlamps are set according to the asymmetrical dipped beam. The light/dark cutoff should touch the boundary line to the left of the center. The intersection point between the left (as far as possible horizontal) and the right rising part of the light/dark cutoff should be on the vertical line through the central mark. The left-hand half of the headlamp may be covered over and uncovered several times to make it easier to determine the intersection point.

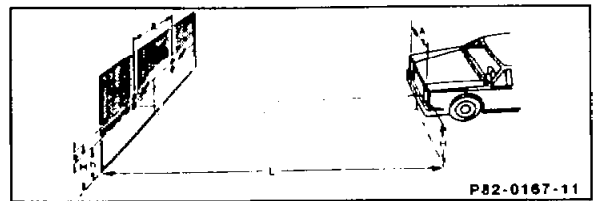

The center of the high beam must be located on the central mark. Variations of 20 cm to the right or left and of 15 cm up or 10 cm down are permissible in each case for headlamps where high and low beam are adjusted together.

C. High beam headlamps

The center of the light beam of the high beam headlamp must be on the central mark.

Note

The high beam headlamp is switched on together with high beam.

- H = Height of headlamp center above base in cm
h = Height of boundary line of test surface above base in cm
e = Setting in cm (see setting table)
 $e = H - h$

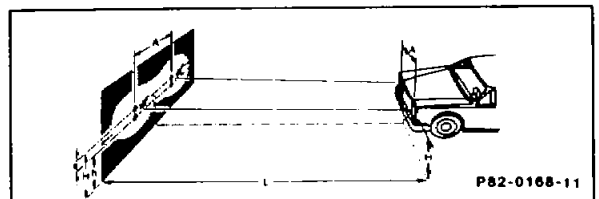

D. Fog lamps

The highest point of the light/dark cutoff in the case of fog lamps should touch the boundary line and should run as horizontally as possible across the minimum width of the test surface. The fog lamps should be adjusted laterally so that the light distribution is as symmetrical as possible to the vertical line through the central mark.

H = Height of fog lamp center above base in cm

h = Height of boundary line of test surface above base in cm

e = Setting in cm (refer to setting table)

$$e = H - h$$

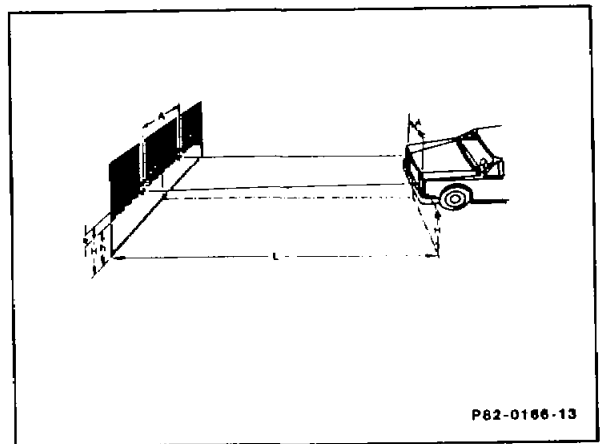

P82-0166-13

E. General on checking headlamp adjustment (USA version as of model year 94)

Headlamp adjustment

The lamp units have auxiliary devices for adjusting the headlamps and checking the adjustment.

- Bubble (1) (level) for height adjustment
- Gauge (2) for lateral adjustment

The bubble (1) is permanently attached to the reflector and aligned with the optical axis of the headlamp.

The scale has a "0" mark in the middle as well as eight increment marks in both directions.

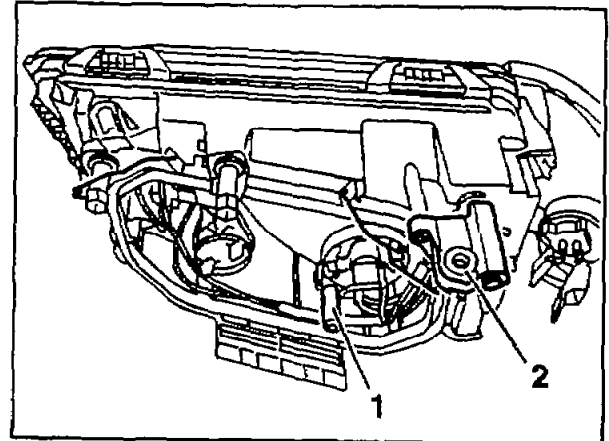

P82-6378-13

Lateral adjustment

A gauge (2) with scale and "0" mark is attached to the housing for checking the lateral adjustment.

Preparation for adjustment

- Correct air pressure in tires.
- Fill fuel tank or load trunk accordingly.
- Slowly drive vehicle onto level surface so that the vehicle level is not changed when the brakes are applied.
- Load driver seat with 75 kg or one person.
- Remove air intake housing for engine (on engines 104, 119 only)
- Remove cover on lamp unit

F. Basic headlamp adjustment (USA version as of model year 94)

Preceding work:

General on checking headlamp adjustment (USA version as of model year 94) according to section E.

Height adjustment

Turn adjustment screw (4) so that the air bubble (1) is at the "0" mark.

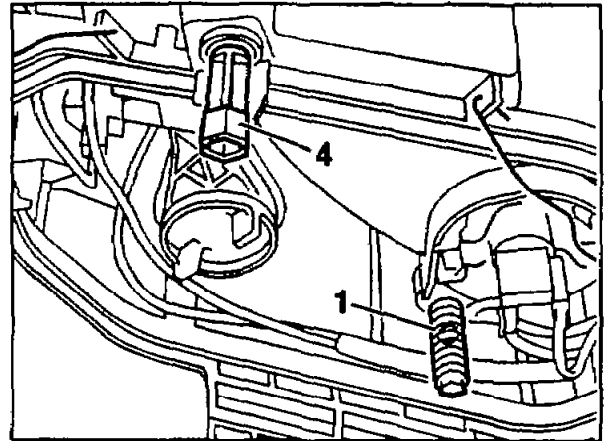

P82-6376-13

Lateral adjustment

Use headlamp adjustment unit and turn adjustment screw (3) accordingly. Press control sleeve (arrow) upward, set to "0" mark and allow to catch.

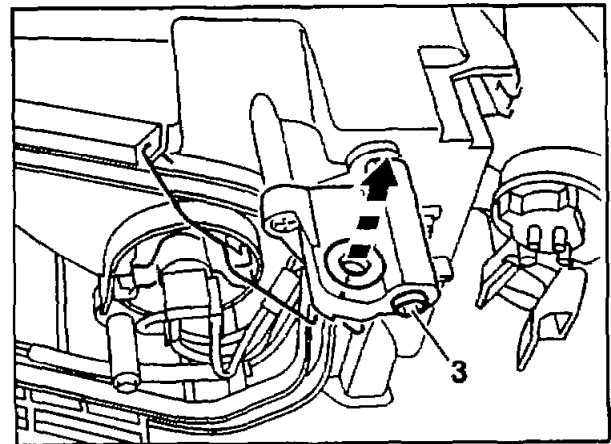

P82-6377-13