

**Content Programmed repairs Front axle**

|  | Coordinates |
|--|-------------|
| 33-85041 Creaking noises at maximum steering angle when suspension compresses (models 124 and 201). . . . .  | B 18        |
| 33-86111 Single knocking noise from the front axle when suspension compresses or upon initial application of brakes (models 124 and 201). . . . .                                | B 18        |
| 33-87031 Knocking noises from right side of front axle when driving over short road surface irregularities (predominantly vehicles with catalytic converter, model 124). . . . . | D 18        |
| 33-87067 Entire vehicle shakes and torsional oscillations at steering wheel, also when braking (model 124 without 4MATIC) . . . . .  | D 18        |
| 33-91111 Cracking noise when braking at front axle . . . . .   | E 18        |

### 33 Front axle

---

|          |   |                    |
|----------|---|--------------------|
| 33-85041 | Creaking noises at maximum steering angle when suspension compresses. | Models 124 and 201 |
|----------|---|--------------------|

---

#### Cause

The stop pin in the steering knuckle makes contact with the control arm at the maximum steering angle. Creaking noises may thus occur when the suspension compresses.

#### Remedy

Production modification: Stop pins with plastic cap as of October 85. If complaints arise, stop pins part no. 201 330 00 80 are available from PEW Sindelfingen.

### 33 Front axle

---

|          |   |                    |
|----------|---|--------------------|
| 33-86111 | Knocking noise from the front axle when suspension compresses or upon initial application of brakes (usually occurs once only each time). | Models 124 and 201 |
|----------|---|--------------------|

---

#### Cause

Insufficient preload force on the control arm mounting on the frame floor due to tolerances in the frame cross member bearing brackets.

#### Remedy

Tighten eccentric bolts to max. 150 Nm (previously 120 Nm).

#### Note

For repair work, use new self-locking hexagon nuts and carefully clean all grease and wax off the threads of the eccentric bolts.



Under no circumstances lubricate the threads of the hexagon nut and eccentric bolt. If the threads are corroded, replace the eccentric bolt.

### 33 Front axle

---

|          |  |           |
|----------|--|-----------|
| 33-87031 | Knocking noises from right side of front axle when driving over short road surface irregularities (predominantly vehicles with catalytic converter). | Model 124 |
|----------|--|-----------|

---

#### Cause

- a) Noises due to the engine compartment panel or lower section of engine encapsulation.
- b) Shortage of grease or play in the plain rubber bearings of the steering idler arm mounting.

#### Remedy

- a) Secure engine compartment panel or lower section of engine encapsulation.
- b) Replace plain rubber bearing (Repair Instructions 46-520). On low-mileage vehicles, lubricate mounting if necessary. Use MB silicone paste 000 989 84 51 (100 g can).

### 33 Front axle

---

|          |   |                       |
|----------|---|-----------------------|
| 33-87067 | Entire vehicle shakes and torsional oscillations at steering wheel. | Model 124 up to 03/87 |
|----------|---|-----------------------|

---

#### Cause

Since March 1987 (phased in) a modified control arm mounting has been installed on the front axle. The control arm has a two-piece mounting of high-damping torsion rubber elements at the front and rear. The distinguishing feature is the rear control arm mounting. This damps the vibration of the vehicle and torsional oscillations of the steering wheel..

Vehicles with rubber mounts of the 1st version must be converted to the modified mounting in accordance with operation no. 33-0526.

#### Modified mounting (2-piece)

- 2 Frame cross member
- 4 Control arm
- 16 Torsion rubber mount
- 16a Clamping sleeve
- 19 Eccentric washer
- 19a Eccentric bolt

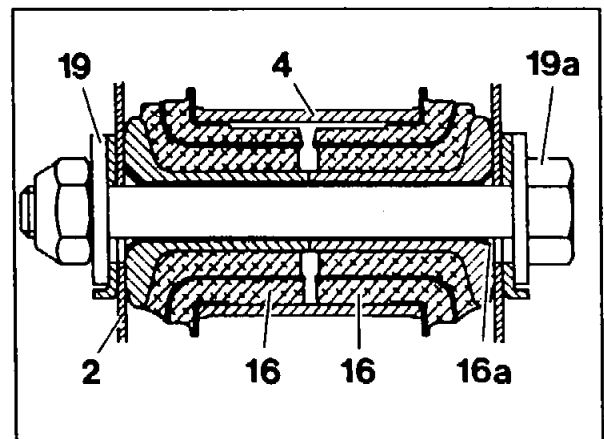

P33-5191-13

### 33 Front axle

---

33-91111 Cracking noise when braking at front axle.

Model

124.036

---

#### Cause

Deterioration in the tightening torque of the retaining bolt for the cross brace on the rear control arm mountings.

#### Remedy

Replace washer part no. 000 433 008 407. Tightening torque 35 Nm.

Damage code for warranty/goodwill claim: 33 003 XX (noises).